

Instruction manual for rescue equipment

Cutters and Combi Tools

STREAMLINE
TECHNOLOGY

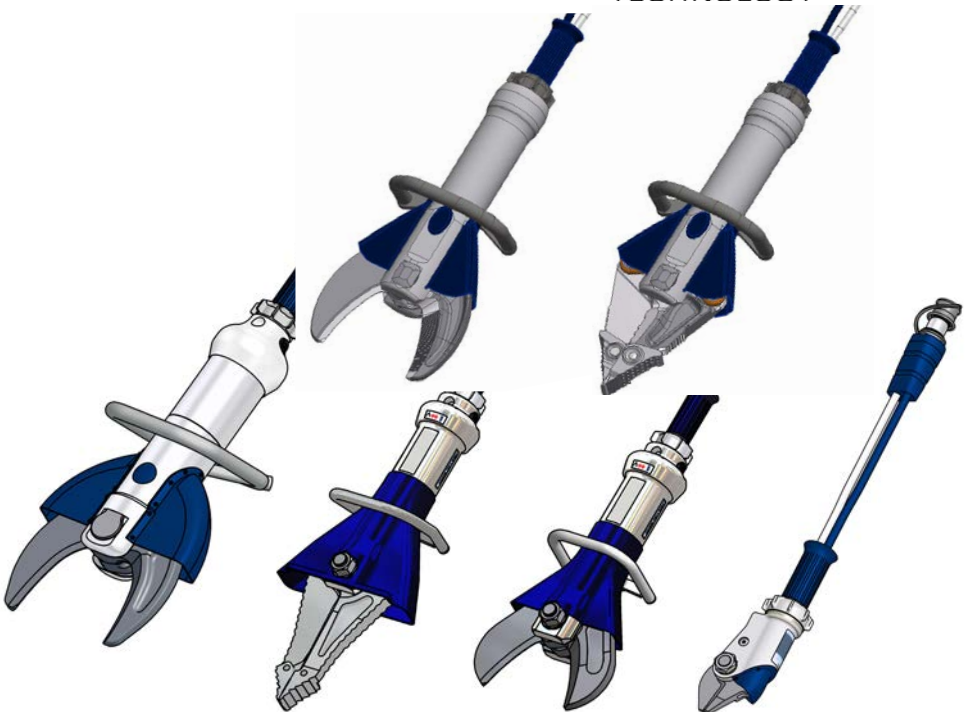

Blade forms:



S x10



S x11
S x12



S x30



SC



722047085 EN
Edition 02.2017
replaces 10.2016

Content	Page
1. Hazard classes	4
2. Product safety	5
3. Intended use	8
4. Description of the functions	9
4.1 <i>Description</i>	9
4.2 <i>Tools in detail</i>	10
4.3 <i>Circuit diagram</i>	12
4.4 <i>Control of the operating movements</i>	12
4.5 <i>Hydraulic supply</i>	12
4.6 <i>Hoses</i>	12
5. Connecting the equipment	13
5.1 <i>General information</i>	13
5.2 <i>Coupling the mono-couplings</i>	13
5.3 <i>Coupling the quick-disconnect couplings</i>	15
6. Operation	15
6.1 <i>Preparatory measures</i>	15
6.2 <i>Operating the star grip</i>	16
7. Cutting, spreading, pulling and squeezing	16
7.1 <i>Safety notes</i>	16
7.2 <i>Cutting</i>	17
7.3 <i>Spreading (combi tools only)</i>	19
7.4 <i>Pulling (combi tools only)</i>	20
7.5 <i>Squeezing (combi tools only)</i>	21
8. Dismantling the equipment / deactivation following operation	22
8.1 <i>Cutters / Combi tools</i>	22
8.2 <i>Hydraulic unit</i>	22
8.3 <i>Hoses</i>	22
9. Maintenance and service	22
9.1 <i>Cutters / Combi tools, overall</i>	23
9.2 <i>Protective equipment</i>	23

Content	Page
10. Repairs	24
10.1 <i>General information</i>	24
10.2 <i>Preventative service</i>	25
10.3 <i>Repairs</i>	26
11. Troubleshooting	42
12. Technical Data	45
12.1 <i>Cutters</i>	45
12.2 <i>Combi tools</i>	52
12.3 <i>Torque of the pivot bolt</i>	54
12.4 <i>Cutting performance</i>	55
12.5 <i>Recommended hydraulic fluid</i>	56
12.6 <i>Operating and storage temperature ranges</i>	56
13. Notes	57

1. Hazard classes

We distinguish between various categories of safety notes. The table below gives you an overview of the assignment of symbols (pictograms) and key words to the specific hazard and possible consequences.

Pictogram	Damage / injury to	Key word	Definition	Consequences
	human	DANGER!	Immediate danger	Death or major injury
		WARNING!	Potentially dangerous situation	Potential death or major injury
		CAUTION!	Less dangerous situation	Minor or slight injury
	device	CAUTION!	Danger of damage to device / environment	Damage to the equipment, damage to the environment, damage to surrounding materials
	-	REMARK	Advice for application and other important / useful information and advice	No injury / damage to persons / environment / equipment



Wear helmet with face protection



Wear safety gloves



Wear safety shoes



Proper recycling



Observe principles of environmental protection



Read and observe operating instructions

2. Product safety

HURST products are developed and manufactured in order to guarantee the best performance and quality when used properly.

Operator safety is the most important aspect of the product design.

Moreover, the operating instructions are intended to help the safe use of HURST products. The generally applicable, legal and other binding regulations pertaining to the prevention of accidents and protection of the environment apply and are to be implemented in addition to the operating instructions.

The equipment may only be operated by persons with appropriate training in the safety aspects of such equipment – otherwise, there is a danger of injury occurring.

We would like to point out to all users that they should read carefully the operating instructions and the instructions contained therein before they use the equipment, and that they should carefully follow such.

We further recommend that a qualified trainer train you in the use of the product.



WARNING / CAUTION!

The operating instructions for the hoses, the accessories and the connected hydraulic equipment must also be observed!

























Even if you have already received instructions on how to use the equipment, you should still read the following safety notes through again.





WARNING / CAUTION!

Ensure that the accessories and connected equipment used are suitable for the max. operating pressure!

	<p>Please ensure that no body parts or clothing get stuck between the visibly moving parts (e.g. blade arms).</p>	<p>It is prohibited to work under load if this load is lifted exclusively by hydraulic equipment. If this work is absolutely imperative, additional mechanical supports must be used.</p>	
	<p>Wear protective clothing, safety helmet with visor, protective gloves</p>	<p>Inspect the equipment before and after use for visible defects or damage</p>	
 	<p>The responsible department is to be informed immediately of any changes (including to the operating behaviour)! If necessary, the equipment is to be deactivated immediately and secured!</p>	<p>Inspect all cables, hoses and screwed connections for leaks and externally visible damage! If necessary, repair immediately! Squirting hydraulic fluid can result in injuries and fires.</p>	
 	<p>In the event of malfunctions, immediately deactivate the equipment and secure it. The malfunction is to be repaired immediately.</p>	<p>Do not carry out any changes (additions or conversions) to the equipment without obtaining the prior approval of HURST.</p>	

 	<p>Observe all safety and danger notes on the equipment and in the operating instructions.</p>	<p>All safety and danger notes on the equipment are to be kept complete in a legible condition.</p>	 
 	<p>Any mode of operation which impairs safety and/or stability of the equipment is forbidden!</p>	<p>Comply with all specified dates or dates specified in the operating instructions pertaining to regular controls / inspections on the equipment.</p>	
 	<p>Safety devices may never be deactivated!</p>	<p>The maximum permitted operating pressure noted on the equipment must not be exceeded.</p>	 
	<p>Before the equipment is switched on/started up, and during its operation, it must be ensured that nobody is endangered by the operation of the equipment.</p>	<p>Only original HURST accessories and spare parts may be used for repairs.</p>	
		<p>Please ensure that, when working with this equipment or during transportation of such, you don't get stuck in the looped hoses and trip.</p>	 
 	<p>When working close to live components and cables, suitable measures must be taken to avoid current transfers or high-voltage transfers to the equipment.</p>	<p>Please note that, when cutting or spreading, tearing or breaking can cause falling material, or sudden removal of such can cause it to suddenly catapult off: necessary precautions need to be taken.</p>	
	<p>The build-up of static charge with the potential consequence of spark formation is to be avoided when handling the equipment.</p>	<p>Only touch any broken-off parts or the cut-off parts wearing protective gloves, since the torn / cut edges can be very sharp.</p>	
	<p>The equipment is filled with a hydraulic fluid. These hydraulic fluids can be dangerous to health if swallowed or their vapours inhaled. Direct contact with the skin is to be avoided for the same reason. Please also note that hydraulic liquids can also have a negative effect on biological systems.</p>	<p>When working with or storing the equipment, ensure that the function and the safety of the equipment are not impaired by the effects of stark external temperatures or that the equipment is damaged in any way. Please note that the equipment can also heat up over a long period of use.</p>	
	<p>Ensure adequate lighting when you are working.</p>	<p>Before transporting the equipment, always ensure that the accessories are positioned such that they cannot cause an accident.</p>	

	Always keep these operating instructions within reach where the equipment is used.	Ensure the proper disposal of all removed parts, left-over oil and hydraulic fluid as well as packaging materials!	 
--	--	--	---

The generally applicable, legal and other binding national and international regulations pertaining to the prevention of accidents and protection of the environment apply and are to be implemented in addition to the operating instructions.

WARNING / CAUTION!

The equipment **is to be used exclusively** for the **purpose stated in the operating instructions (see chapter “Proper Use”)**. Any other or further use is **not considered proper use**. The manufacturer / supplier is not liable for any damages resulting from improper use. The user bears sole responsibility for such. Observance of the operating instructions and compliance with the inspection and maintenance conditions are part of the proper use.

	Never work when you are overtired or intoxicated!	
---	--	---

3. Intended use

HURST “SC” combi tools and HURST “S” cutters are designed specifically for rescuing victims in traffic, rail or air accidents and for making rescues from buildings. They serve the purpose of freeing injured people in accidents e. g. by cutting doors, roof bars and hinges. By using the HURST combi tools, trapped persons can also be freed e. g. by spreading doors and / or by removing obstacles with the aid of a chainset. Basically, the combi tools can be used to cut, pull, spread, squeeze and lift.

Basically, HURST cutters can only be used to cut objects. All objects which are to be worked on are to be secured using stable supports or substructures.

Sample applications of the combi tools:



Sample application of the cutters:



HURST cutters and combi tools can also be used under water at a depth of up to 40m (131 ft).



CAUTION!

In this case, you must strictly observe any leaks in order to avoid threats to the environment.



CAUTION!

All objects which are to be worked on are to be secured using stable supports or substructures.



WARNING / CAUTION!

The following may not be cut / squeezed:

- **live cables**
- **hardened** parts such as springs, spring steels, steering columns and rollers
- tubes / hoses under gas or liquid pressure,
- compound materials (steel/concrete)
- explosive bodies such as airbag cartouches



NEVER operate the rescue equipment at a higher operating pressure than that stated in the chapter "Technical data". A higher setting can result in material damage and/or injuries.

HURST rescue equipment may only be used in areas at risk of explosion if an explosion has been prevented by appropriate measures. You must also take into account that sparks may be created, for example by cutting an object.

When working in areas at risk of explosion, all applicable legal, national and international regulations, standards and safety rules for avoiding explosions must be observed without limitation!

Spare parts and accessories for the rescue tool can be ordered from your authorised HURST-dealer!

4. Description of the functions

4.1 Description

The equipment is designed such that, via a hydraulically activated piston, two equal, opposite blade arms are symmetrically opened / closed by mechanical joints, thereby spreading, squeezing, pulling or cutting objects.

All cutters and combi tools ensure full load-holding function when disconnected from the hydraulic supply (e. g. when being unintentional decoupled; defective hose, and so on).

4.2 Tools in detail

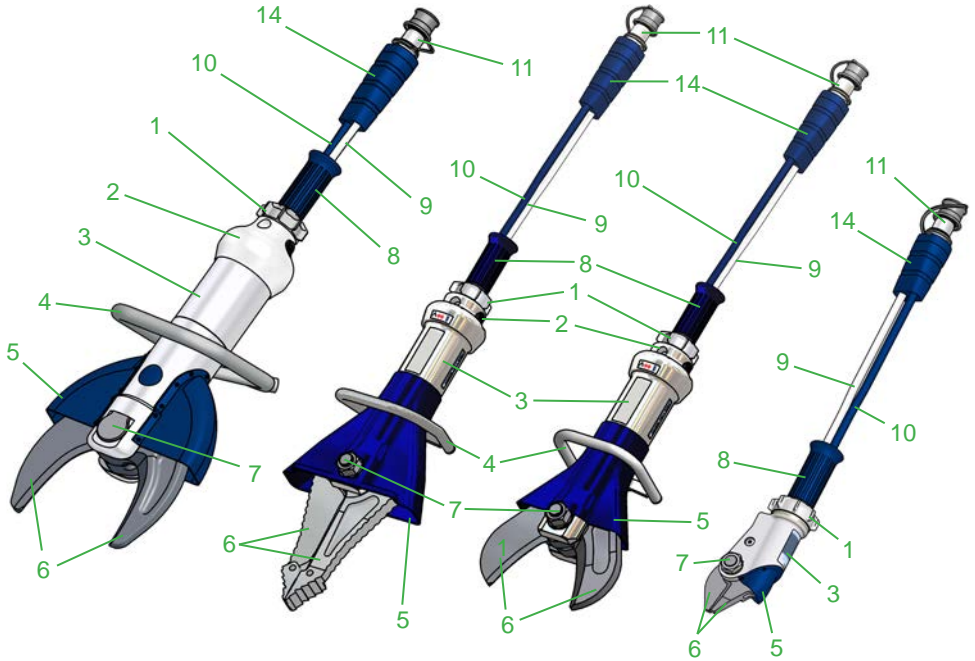

quick-disconnect coupling system:

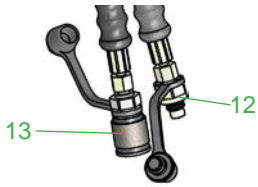

- 1 Star grip
- 2 Control valve
- 3 Body of rescue tool
- 4 Handle
- 5 Hand guard
- 6 Blade arm
- 7 Pivot bolt with self-locking nut
- 8 Handhold
- 9 Pressure hose
- 10 Return hose
- 11 Mono-coupling male
- 12 Quick-disconnect coupling (male)
- 13 Quick-disconnect coupling (female)
- 14 Kink-protection

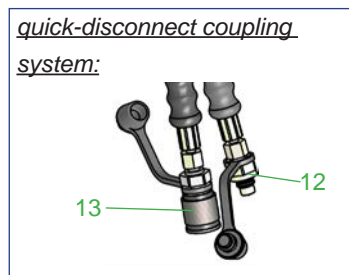
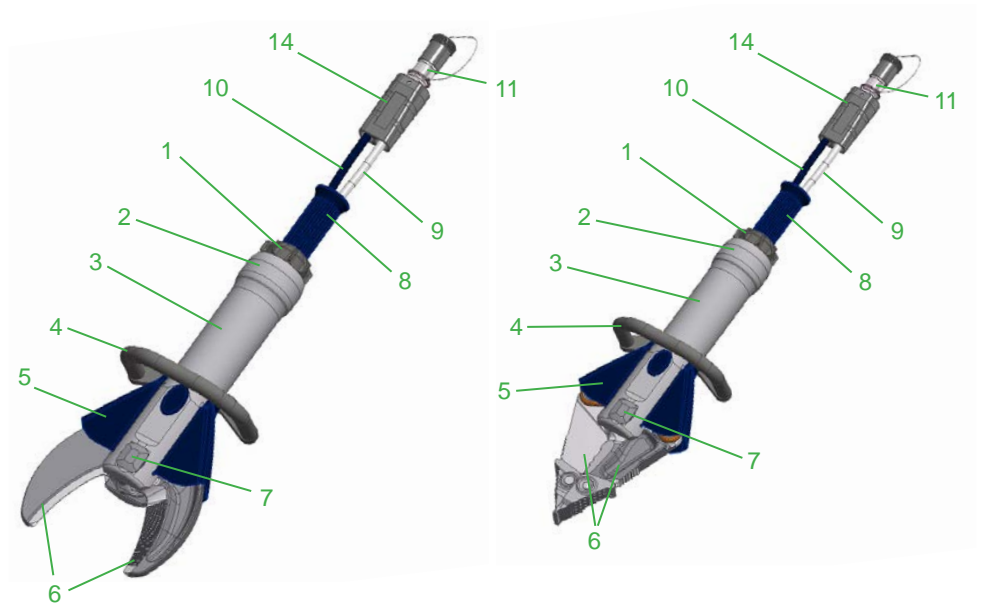

- 1 Star grip
- 2 Control valve
- 3 Body of rescue tool
- 4 Handle
- 5 Hand guard
- 6 Blade arm
- 7 Pivot bolt with self-locking nut
- 8 Handhold
- 9 Pressure hose
- 10 Return hose
- 11 Mono-coupling male
- 12 Quick-disconnect coupling (male)
- 13 Quick-disconnect coupling (female)
- 14 Kink-protection

4.3 Circuit diagram

To enable comprehension of the function, a simplified hydraulic cylinder of the rescue equipment (A) + hand valve (B) are depicted here.

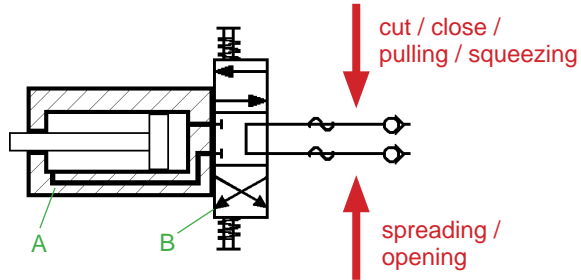

4.4 Control of the operating movements

The spreading arms movement is controlled via the star grip of the mounted valve. (see cover, item 1 and, below, figure 3).



fig. 3

4.5 Hydraulic supply

A HURST motor pump or hand pump only may be used to drive the equipment. If the pump unit is a different make, you must make sure that it complies with HURST specifications, otherwise potential dangers may occur which are not the responsibility of HURST. Ensure in particular that the authorised operating pressure for HURST equipment is not exceeded.



REMARK:

Before you use pumps from a different manufacturer, you must contact HURST or an authorised dealer.

4.6 Hoses

The pump unit and the rescue tool are connected by hoses.

5. Connecting the equipment

5.1 General information

There are two short hoses on the side of the equipment: they are connected to the pump unit via two hoses. All hose assemblies are marked with a colour and have couplings to enable unmistakable connection.



REMARK:

The devices can be equipped with different coupling systems. They differ only by the article number and not by the designation. Of course the coupling systems can also be reequipped at a later time.



WARNING / CAUTION!

Before connecting the equipment you have to pay attention that **all used components** are suitable to the **max operation pressure of the pump unit!** In the case of doubt you **have to inquire HURST** directly!

5.2 Coupling the mono-couplings

The equipment is connected to the hydraulic pump via mono-coupling halves (male and female).

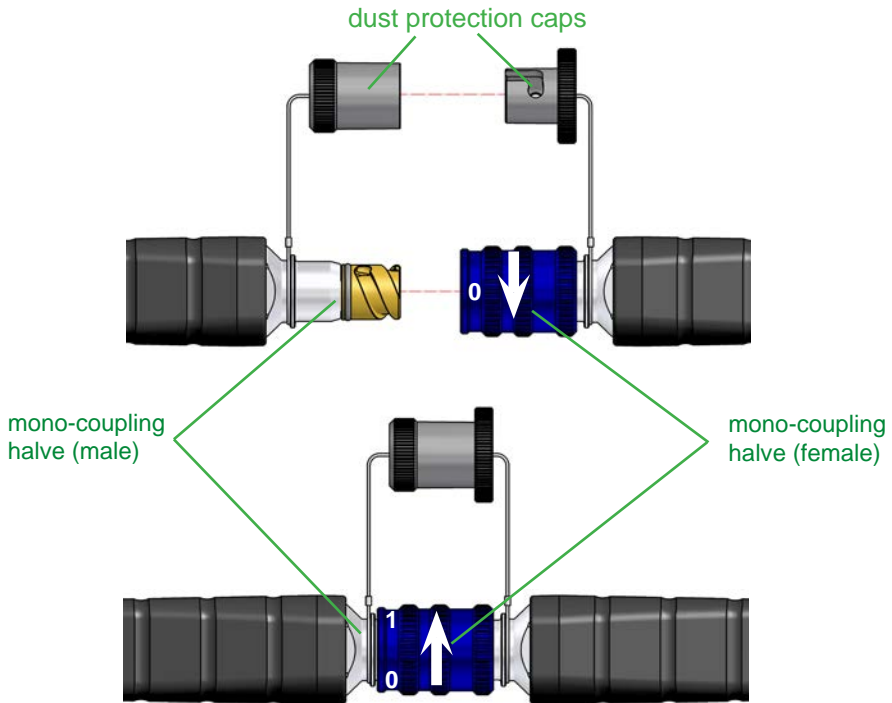

Before coupling, remove dust protection caps, then connect male and female, and turn the locking sleeve of the female to direction „1“ until the locking sleeve locks into place. The connection is now in place and secure. Decoupling is by turning the locking sleeve to direction „0“.
The equipment can also be coupled under pressure provided the connected equipment is not activated.



REMARK:

We **recommend** coupling the coupling halves in a **pressureless** state, when working in areas with low ambient temperature and the usage of extension hose assemblies / hose reels, otherwise coupling could need very high expenditure of force.

To protect them from dust, the accompanying dust protection caps must be put back on.

Fitting the dust protection caps:

The “A” dust protection caps have two internal pins “B”. The dust protection caps must be placed on the coupling pins in such a way that the pins are guided in the “C” grooves. Fasten the screw to the limit stop to fix the dust protection caps on the coupling pins.

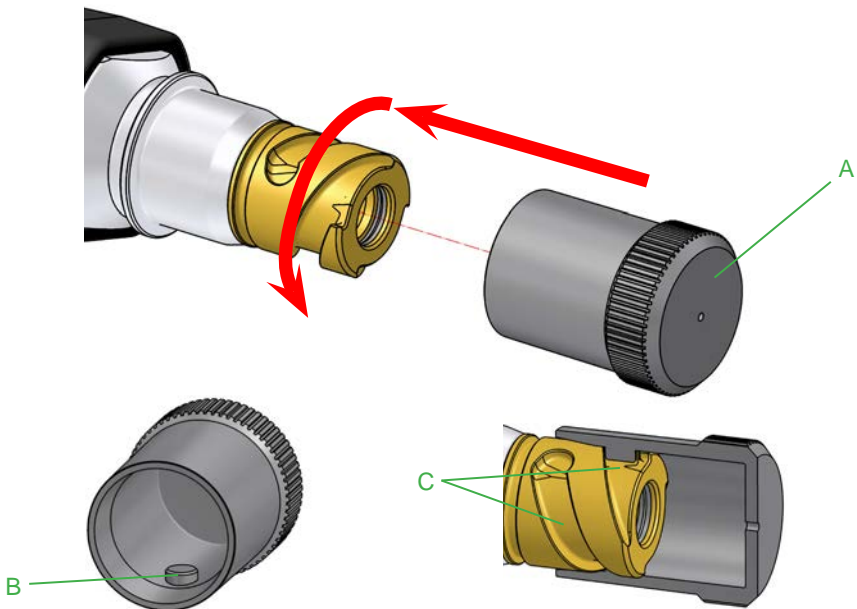

WARNING/CAUTION!

The mono-couplings **may not be screwed off** the hose assemblies and / or the hose assemblies be **confused!**



5.3 Coupling the quick-disconnect couplings

The equipment is connected to the hydraulic pump via quick-disconnect-coupling halves (male and female).

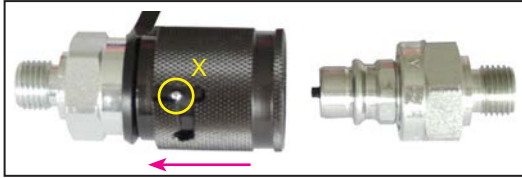

Before coupling unlock the connect socket by turning the sleeve into position X. Retract sleeve and connect plug and socket. Release sleeve and turn it into position Y. Now the connection has been made and locked. Uncoupling is done in the reverse order.



CAUTION!

Always connect the return line first and afterwards the supply line!



REMARK:

Coupling of the devices is only possible, when the hoses are **depressurized**.

To protect them from dust, the accompanying dust protection caps must be put back on.



WARNING/CAUTION!

The quick-disconnect-couplings partly have special functions. Therefore it is not allowed to **screw them off** from the hoses or to **exchange** them!



6. Operation

6.1 Preparatory measures

6.1.1 Commissioning

Before commissioning and following repairs, the equipment must be deaerated.

- Connect the equipment to the hydraulic pump (see chapter “Connecting the equipment”).
- Open / close the blade arms of the equipment without any load at least twice (see chapter “Operation of the star grip”).



REMARK:

We recommend that during the deaeration, the attached aggregate for the hydraulic supply should stand on a higher level than the body of the rescue tool.

Recommended procedure for the deaeration of the rescue tool:

- 1.) open and close fully with the blade arms facing **upwards**.
- 2.) open and close fully with the blade arms facing **downwards**.
- 3.) open and close fully with the blade arms facing **upwards**.
- 4.) open and close fully with the blade arms facing **downwards**.

6.1.2 Inspection of the pump unit

➔ See separate operating instructions for the relevant unit (or for the hand pump).



REMARK:

Before each start-up of the hydraulic unit you have to make sure that the actuating valves are set to depressurized circulation.



REMARK:

Before coupling the quick-disconnect couplings, the actuating valves of the hydraulic unit are set to depressurized circulation.

If you use mono-couplings, you can also couple when the hoses are pressurized!

6.2 Operating the star grip

Opening the device ():

Turn the star grip in a clockwise direction (in the direction of the relevant symbol) and keep in this position.

Closing the device ():

Turn the star grip in an counterclockwise direction (in the direction of the relevant symbol) and keep in this position.

“Dead-man’s” function:

Following release, the star grip automatically returns to the central position, guaranteeing the full load-holding.

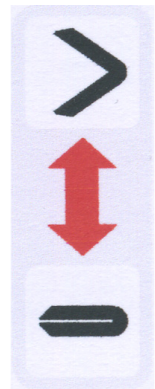

7. Cutting, spreading, pulling and squeezing

7.1 Safety notes

Before rescue works can commence, the position of the obstacle must be stabilised. You must ensure an adequate substructure and / or adequate support of the object. World-wide, safety guidelines pertaining to the specific country are to be observed and complied with.

In areas at risk of explosion, the equipment can only be used if an explosion has been prevented by appropriate measures.

The following are to be worn when working with the rescue equipment:

- protective clothing,
- safety helmet with visor or protective goggles,
- protective gloves
- and, if necessary, ear protection

Before activating the rescue equipment, always ensure that there is no danger to persons either involved / uninvolved in the action by the movement of the rescue equipment or by flying fragments. Further avoid unnecessary damage to property belonging to others, objects not involved by the rescue equipment / flying fragments.



Reaching between the blade arms is strictly forbidden!



WARNING / CAUTION!

The particular effect of the force of the rescue equipment during operation could cause pieces of the vehicle to break off or fly off, posing a danger to persons. Those not involved in the rescue operation should therefore **keep at a distance appropriate to the situation**.

7.2 Cutting

The blades should be positioned at a 90° angle to the object to be cut, if possible.

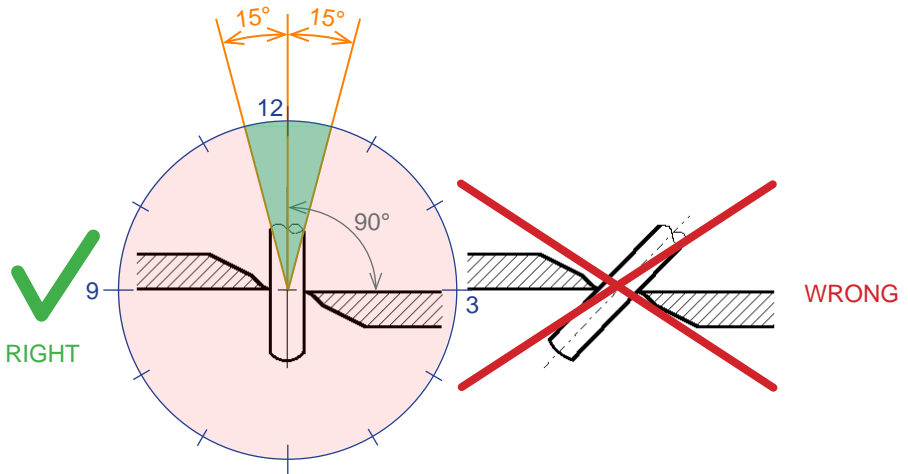

Higher cutting capacities can be achieved by cutting as close as possible to the blade's pivot point.



RIGHT

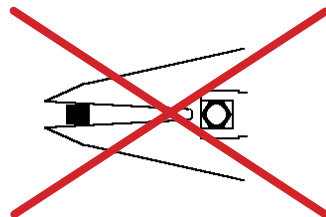
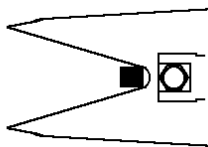

WRONG

During cutting, the gap between the blade tips (in the crosswise direction) may not be exceeded, otherwise the blade is in danger of breaking:

Cutter / combi tool	max. gap on the blade tips [mm] / [in.]
S 120	2 / 0.08
S 312	3 / 0.12
S 330	
S 510	5 / 0.20
S 511	3 / 0.12
S 530	5 / 0.20
S 700	3 / 0.12
SC 358	
SC 557	



CAUTION!

Avoid cutting particularly high-strength parts of the vehicle's bodywork (e.g. side-impact protection): this almost always causes damage to the cutter / combi tool!

Cutting with SC 358

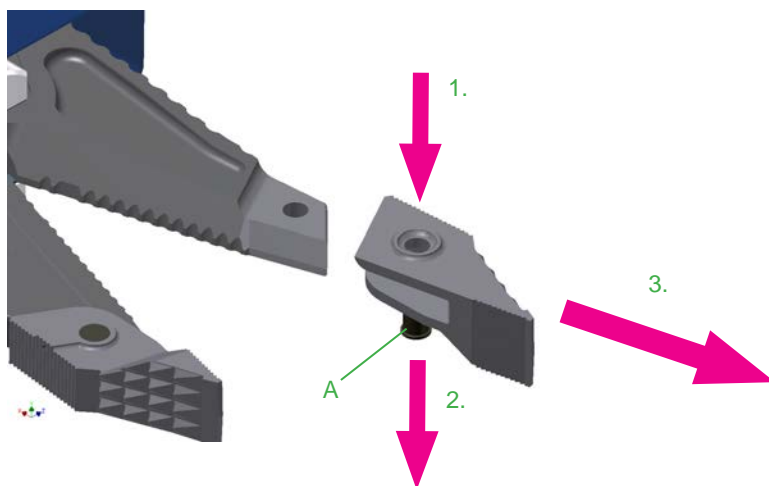

The spreader tip of the SC 358 can be removed. This prevents the material from becoming stuck between the spreader tips, hindering the cutting process.

Removing the spreader tip

Step 1:

To remove the spreader tips, first push out bolt "A" a little, using a finger or an object. A fair amount of force needs to be applied initially, as the bolt has a ball catch to prevent it from falling out unintentionally.

Step 2:

The bolt can then be gripped by the flange and pulled out up to the limit stop. The limit stop will prevent the bolt from being pulled out entirely. This means that it cannot be lost.

Step 3:

Pull the spreader tip forwards to remove it.

Attaching the spreader tip:

Attachment of the spreader tip takes place in the reverse sequence.



Ensure that the bolt is always completely pushed in and engages. If the bolt has not engaged, this may result in the tip inadvertently coming loose while in use. This in turn could result in damage to the rescue equipment. The rescue device could also slip or parts could be flung off, resulting in injuries to both the operator and the crash victim.

Care must also be taken that the bolt does not inadvertently come loose while the device is in use.

7.3 Spreading (combi tools only)

Use the front area of the tips for increasing the gap only. Full spreading capacity can be achieved when approximately half of the grooved area of the tips is used. The greatest force is created in the rear area of the spreading range of the combi blade.

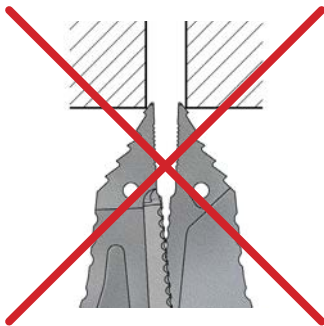

Working surface is too small, tips slip off. Only for increasing the size of a gap (not suitable for spreading)

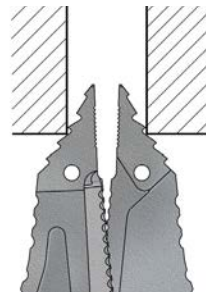

Tips get a safe grip.

7.4 Pulling (combi tools only)

You may only use HURST chain sets for pulling purposes.

Before the pulling process can be performed, ensure that the bolt and hook fit correctly to prevent the chain from slipping.

Only chain sets in perfect condition may be used! The pull chains are to be inspected at least once per year by an expert!

See separate operating instructions for the relevant HURST chain set in order to correctly attach, affix and use the chain sets.

The connection pieces of the HURST chain sets are affixed to the boreholes A on the blades using load bolts (see figure, right).

Chain sets:

for SC 358: KSV 11

for SC 557: KSV 13

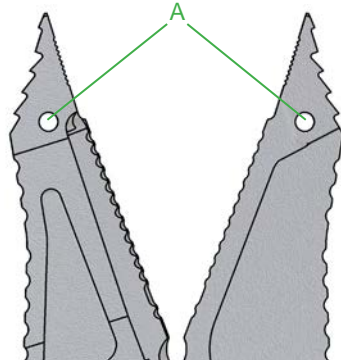

Pulling with SC 358

To use the SC 358 for pulling, the spreader tip must first be removed (see 7.2).

The pulling attachment "A" is then mounted.

First pull out the bolt of the pulling attachment up to the limit stop, slip the pulling attachment onto the arm and push in the bolt completely until it engages (also see Section 7.2, "Removing and attaching the Spreader Tip") in this regard.

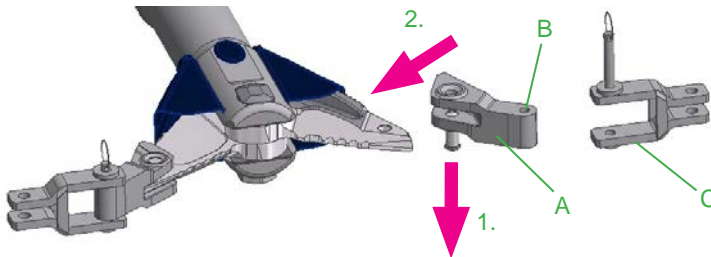

The matching chain lock "C" can then be fixed to hole "B" of the pulling attachment (see separate operating instructions for chain lock).

7.5 Squeezing (combi tools only)

Basically, squeezing can only be carried out in the area of the tips (see figure below).

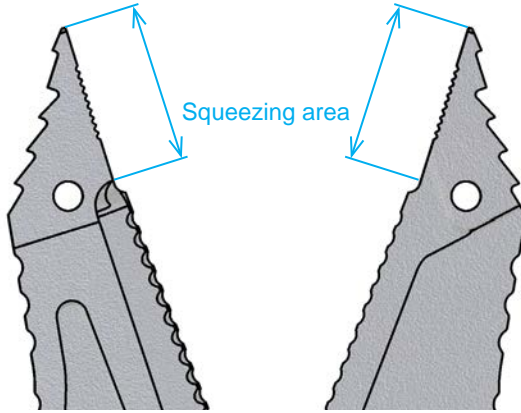

8. Dismantling the equipment / deactivation following operation

8.1 Cutters / Combi tools

Once work has been completed, the blade arms are to be closed so that there is a tip distance of just a few mm. This relieves the hydraulic and mechanical strain on the equipment.



REMARK:

Never store the cutter / combi tool with fully closed blade arms! The complete closure of the blade arms can cause hydraulic and mechanical stress to build up again.

Free the rescue equipment of any stubborn dirt which may have become attached during use.

If the equipment is to be stored for a longer period of time, the exterior is to be cleaned completely and the mechanically mobile parts are to be lubricated.

Avoid storing the rescue equipment in a damp environment.

Observe also the separate manual for the hydraulic hoses.

8.2 Hydraulic unit

Upon completion of work, the unit must be deactivated.

8.3 Hoses

First of all, decouple the pressure hose then the return hose as described in chapter "Connecting the equipment".

Ensure that you put the dust protection caps back on to the couplings.

9. Maintenance and service

The equipment are subject to very high mechanical stresses. A visual inspection is to be carried out after every use: however, at least one visual inspection is to be carried out every six months. These inspections enable the early detection of wear and tear, which means that punctual replacement of this wearing parts prevents breakages from occurring. Also regularly check the torque of the pivot bolt. (Torque M_A see "Technical Data")



CAUTION!

Clean off any dirt before controlling the equipment!



WARNING / CAUTION!

In order to carry out maintenance and repair works, tools appropriate for the job and personal protecting equipment are essential.



9.1 Cutters / Combi tools, overall

Inspections to be carried out:

Visual inspection

Cutter / combi tool

- Opening width of the blade arms on the tips (see chapter “Technical data”),
- General tightness (leaks),
- Operability of the star grip,
- Existence and stability of handle,
- Labels completely existent and legibly,
- Covers in perfect condition,
- Control of the torque of the pivot bolt (torque M_A see “Technical Data”),
- Couplings must be easy to couple,
- Dust protection caps must be available.

Blade arms

- Blade arms free of tears and without any chipped spots or deformations on the cutting surfaces,
- Cutting surfaces go on top of each other without making contact,
- Bolts and retaining rings of the blade arms must be present and in correct working order,
- Grooving of the tips must be clean and squared, and not have any tears (applies to combi tools)

Hoses (see also the separate manual for the hydraulic hoses.)

- Visual control for visible damage,
- Control for leaks.
- Check date of manufacture (note the replacement period of 10 years)

Function test

- Opening and closing function flawlessly upon activation of the star grip,
- no suspicious noises.
- no further movement of the blade arms upon interruption of the valve activation during the process (“dead-man’s” function)

9.2 Protective equipment

- Control of the protective equipment on / around the rescue equipment, especially the hand guard of the moveable parts (they must be free of tears!).

10. Repairs

10.1 General information

Servicing may only be carried out by the manufacturer or personnel trained by the manufacturer and by authorised HURST dealers.

Only HURST spare parts may be used to replace all components (see spare parts list) since special tools, assembly advice, safety aspects, inspections might have to be complied with (see also chapter "Maintenance and Service").

During assembly, ensure the complete cleanliness of all components, since dirt can damage the rescue equipment!



WARNING / CAUTION!

Protective clothes must be worn when repairs are being carried out, since parts of the units can also be pressurised in an idle state.



REMARK:

Please always register your tool on the HURST website. Only then are you entitled to the extended guarantee.



REMARK:

Before you use couplings from a different company, you must contact HURST or an authorised dealer.



REMARK when using the quick-disconnect-coupling system:

Overpressure protection of the rescue equipment

(model with yellow coupling nipple on the return hose)

If the equipment's short hoses are not connected to a unit, temperature increases can inadvertently cause pressure to build up in the equipment. Hence, the return hose of the equipment is equipped with a safety coupling (quick-disconnect coupling male, yellow). Unwanted overpressure (approx. 1.5 MPa) is automatically released via this nipple: hydraulic fluid leaks.

Should an hydraulic fluid leak on the coupling male be more frequent, please contact your dealer or HURST itself.

If couplings from a different company are used which do not have this function, the overpressure protection can react in the valve of the rescue equipment. Hydraulic fluid leaks in the area of the star grip. Following the reduction in pressure, the valve is once again tight.

Should the valve leak permanently, please immediately contact your dealer or HURST itself.



CAUTION!

Because HURST rescue equipments are appropriate for highest achievements, only components may be exchanged, which are specified in the spare parts list of the appropriate equipment.

Further components of the equipment may only be exchanged, when:

- you have participated on a appropriate HURST service training.
- you have the explicit permission of the HURST Service department (After inquiry, examination for the distribution of permission. Examination in each individual case necessarily!)

10.2 Preventative service

10.2.1 Care regulations

The exterior of the equipment is to be cleaned from time to time in order to protect it from external corrosion. Oil is to be applied to the metallic surfaces.

10.2.2 Function and load test

If there is any doubt regarding the safety or reliability of the equipment, a function and load test must also be performed.

HURST offers appropriate test equipment to this end.

10.2.3 Changing the hydraulic fluid

- The hydraulic fluid must be changed after the equipment has been used approx. 200 times / after three years at the latest.
- It must always be changed whenever the hydraulic fluid for the accompanying pump (motor / hand pump) is changed. This is to prevent the fresh hydraulic fluid from becoming contaminated by the used fluid from the rescue equipment.

Procedure:

1. Close blade arms (until the tips are almost touching).
2. Change the hydraulic fluid of the pump. Please observe the separate operating instructions for the pump being used!
3. Screw off the return hose on the pump:
 - **when the hose connection is directly into the pump:**
completely unscrew the connection nut of the connection piece of the blue return hose.
 - **when the hose connection is via mono-coupling to the pump:**
remove the kink-protection from the mono-coupling (male).
completely unscrew the connection nut of the blue returnhose on the mono-coupling (male).
 - **when the hose connection is via quick-connect-coupling to the pump:**
completely unscrew the connection nut on the quick-disconnect-coupling of the blue return hose.
4. Put the return hose into a separate collecting basin for the hydraulic fluid still in the equipment.
5. Slowly open the tool (the pump must be working during this time). The old hydraulic fluid from the ring space side runs via the return hose into the separate collecting basin, and is to be disposed of in the same manner as the old hydraulic fluid of the pump.
6. Switch the pump off (motor pump) / no longer activate it (e.g. hand pump).
7. Reconnect the return hose to the pump:
 - **when the hose connection is directly into the pump:**
screw the connection nut of the connection piece of the blue return hose back on.
(Please observe the necessary torque of $M_A = 40 \text{ Nm!}$)
 - **when the hose connection is via mono-coupling to the pump:**
screw the connection nut of the blue return hose back onto the mono-coupling (male).
(Please observe the necessary torque of $M_A = 40 \text{ Nm!}$)
Pull back the kink-protection on the couplings as far as the limit stop.
 - **when the hose connection is via quick-connect-coupling to the pump:**
screw the connection nut back onto the quick-disconnect-coupling of the blue return hose.
(Please observe the necessary torque of $M_A = 35 \text{ Nm!}$)
8. Deaerate the rescue tool as described in the chapter "Preparatory measures".

10.3 Repairs

10.3.1 Changing the blade and hand guard of cutters S 3xx (except S 312) and S 5xx

1. First of all, carefully clean the rescue equipment.
2. Next, close the blade arms so that the tips are almost touching.



REMARK:

The blade bolts are only accessible when the blade arms are almost touching

Further procedure:

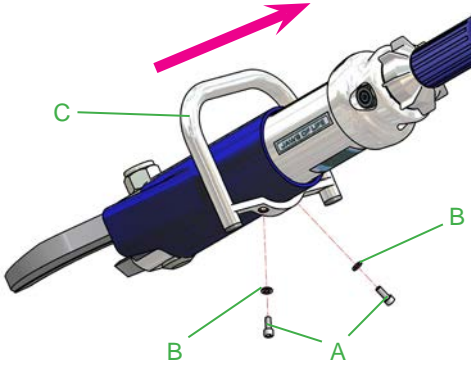

3. Remove screws A and spring washers B of handle C. Then, the handle can be removed in the direction of the connecting hoses of the device.

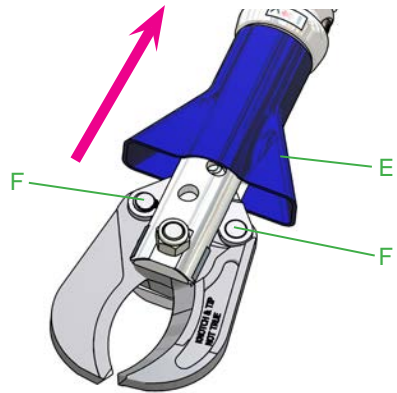

4. Push the hand guard E in the depicted direction until the safety bolts F are easily accessible.

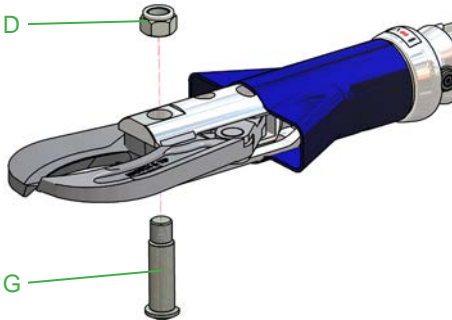

5. Remove self-locking nut D and push the pivot bolt G out.

6. Remove the retaining rings H and push out bolt J.

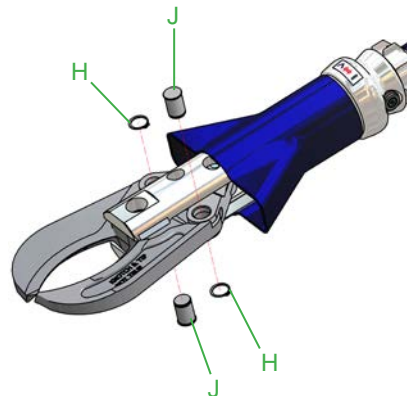

7. Now, you can remove blade K and sliding plates L.

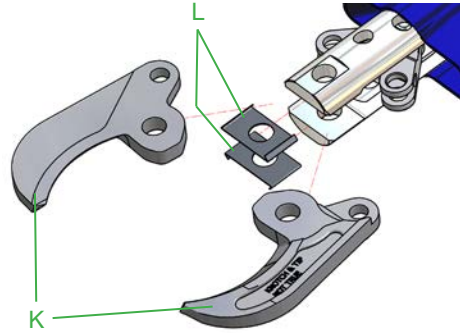

8. Fold in the lever elements M.

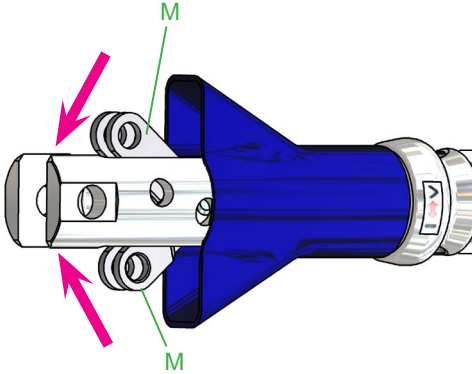

9. Finally, remove the hand guard E from the equipment as depicted.

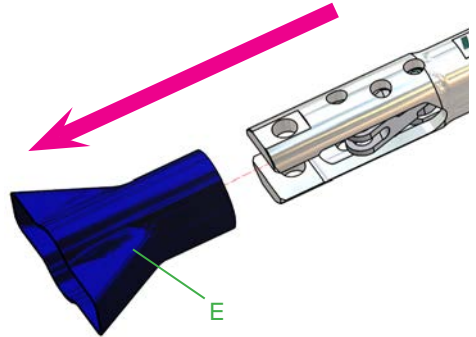

10. In order to assemble the new parts, points 3-9 are to be carried out in reverse order.



CAUTION!

Don't forget to apply HURST special grease to all sliding surfaces.



REMARK:

If you only wish to change the blades, only carry out points 1, 2 as well as points 5., 6. and 7.

There is no need to dismantle the handle and reset the hand guard if you pull back / bend the front area of the hand guard such that you can reach the retaining rings and bolts.



CAUTION!

The nut of the pivot bolt and the pivot bolt itself will be adapt together by a special procedure, therefore they have only be changed as a set by usage of a new set! Because of the special procedure an unscrewing of the nut while working will be minimized and a resulting blade crack will be prevented.

The nuts can be unscrewed and thigtend up to 10 times without affecting the service performance!

10.3.2 Changing the blades of cutter S 120

1. First of all, carefully clean the rescue equipment.
2. Next, close the blade arms so that the tips are almost touching



REMARK:

The blade bolts are only accessible when the blade arms are almost touching

Further procedure:

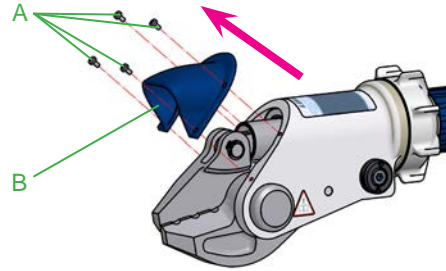

3. Remove screws A and hand guard B.

4. Remove nut C and Nord-Lock washer D (stuck together). Then push the pivot bolt E out.

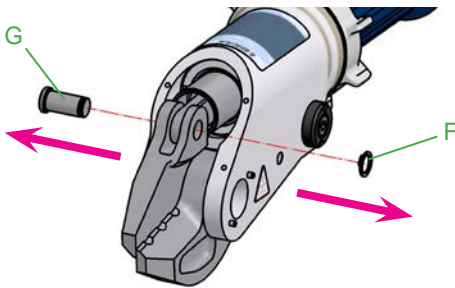
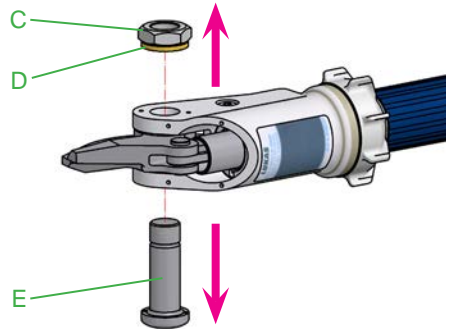

5. Remove retaining ring F and push blade bolt G out.

6. Remove fitting screw H.

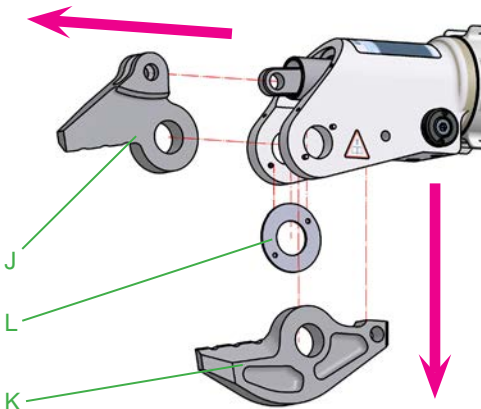
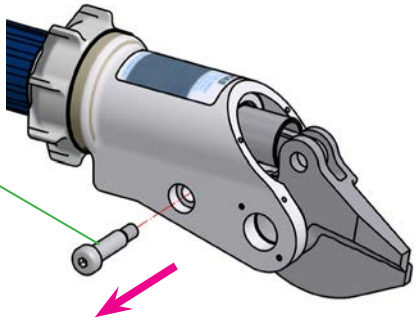

7. You can now remove blades J and K, remove the sliding washer L and, if necessary, replace blades and/or sliding washer.



REMARK:

To remove the sliding washer, it must first of all be removed from the roll pins (see detail I).

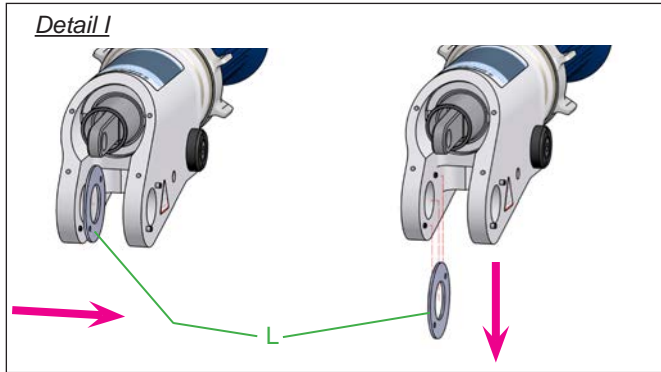

8. Assembly of the new blades is carried out in reverse order.

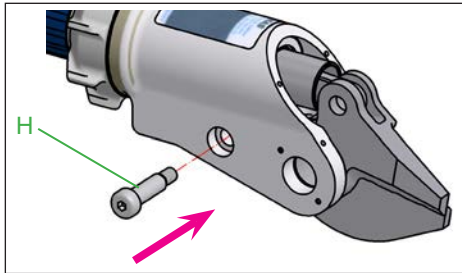

REMARK:

Tighten the fit bolt H during assembly with a torque of $M_A = 40 \text{ Nm!}$



REMARK:

When assembling the pivot bolt, ensure that it is fixed with the roll pins M as shown in detail II, and that it is prevented from twisting.

Detail II

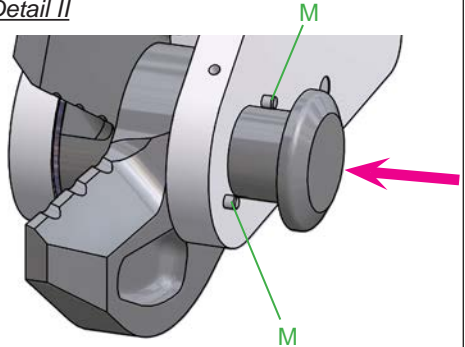

REMARK:

Should the adhesion between the Nord-Lock washer and the nut become undone, they can still be used. However, during assembly, always ensure that the serration of the nut and the Nord-Lock washer are positioned on top of each other (see detail III).

Detail III

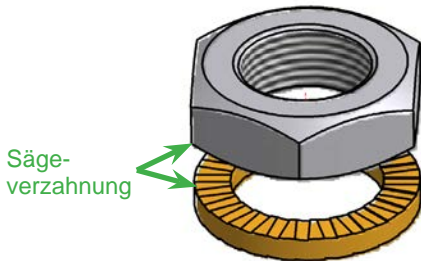

CAUTION!

Don't forget to apply HURST special grease to all sliding surfaces.

10.3.3 Replacing blades, protective covers and handles on the cutter S700

Components to be replaced	Required work steps
Protective cover	1. - 3. and 8.
Pivot bolt	1. - 5. and 8.
Handle	1. - 6. and 8.
Blade	1. - 7. and 8.

Work steps:

1. First of all, carefully clean the rescue equipment.
2. Next, close the blade arms so that the tips are almost touching.

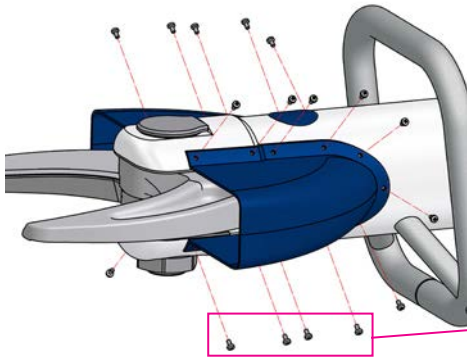

3. Remove the fixing screws "A" and remove the protective cover "B" and the cover caps "C".

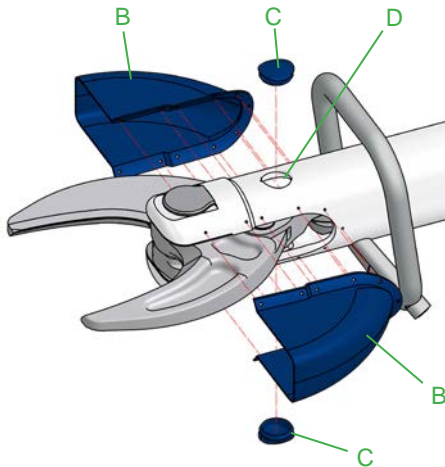
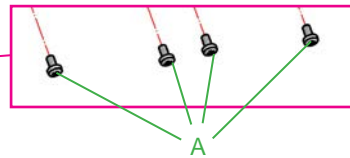

4. Move the blade arms on the unit until the pin "E" and the locking rings "F" can be accessed through the hole "D".
Turn the unit off and disconnect it from the hydraulic supply (uncouple).

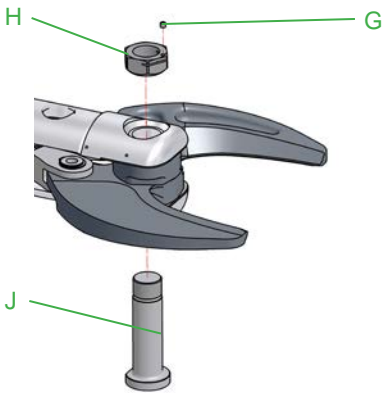
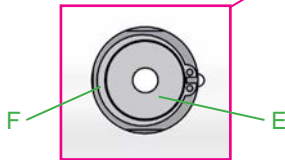
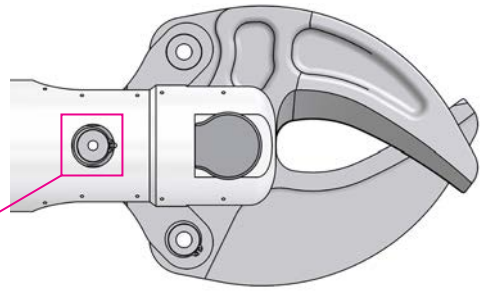

5. First remove the grub screw "G", then the central bolt nut "H" and then pull out the pivot bolt "J".

6. Release the fixing screws "K" and remove them. The handle "L" can now be pulled out forwards over the blades.

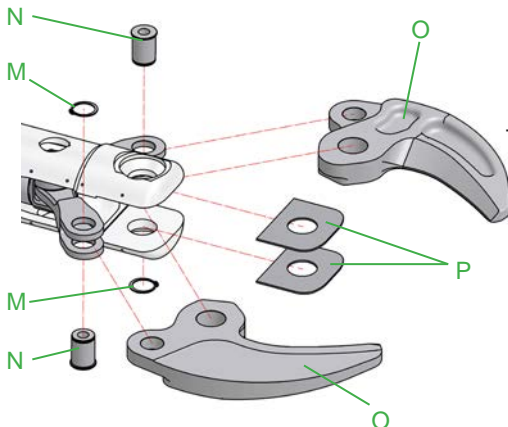
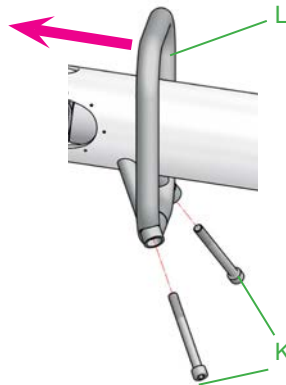

7. Remove the locking rings "M" and push the pin "N" out. You can then pull out the blades "O" and the slide plates "P".

8. The work steps must be carried out in reverse order to fit the new parts.



CAUTION!

Don't forget to apply HURST special grease to all sliding surfaces.



NOTE:

The torque required can be taken from the spare parts list of your particular unit.

10.3.4 Changing the blade and hand guard of combi tool (except SC 358)

1. First of all, carefully clean the rescue equipment.
2. Next, close the blade arms so that the tips are almost touching.



REMARK:

The blade bolts are only accessible when the blade arms are almost touching

Further procedure:

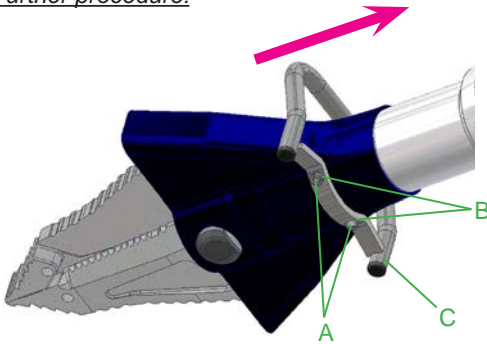

3. Remove screws A and spring washers B of handle C.
The handle can then be removed in the direction of the connecting hoses of the device.

4. Remove nut D and washer E from the pivot bolt.

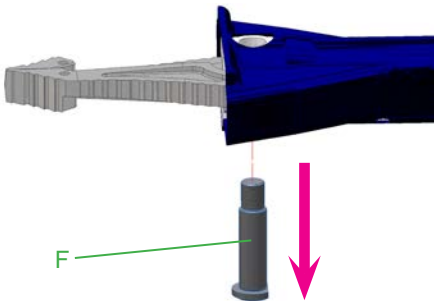
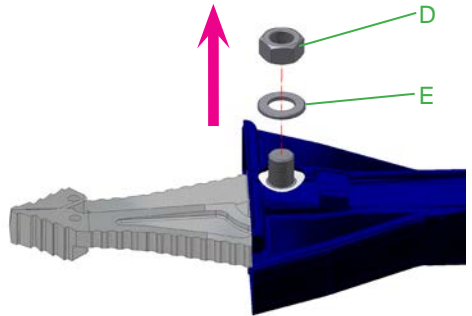

5. Press the pivot bolt F out.

6. Push the hand guard G in the depicted direction until the safety bolts H are easily accessible.

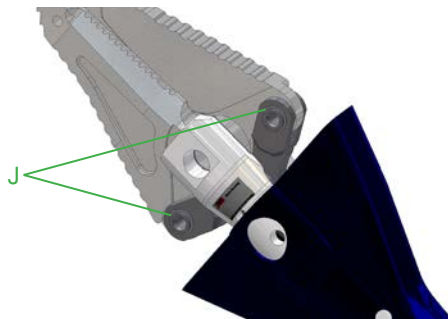
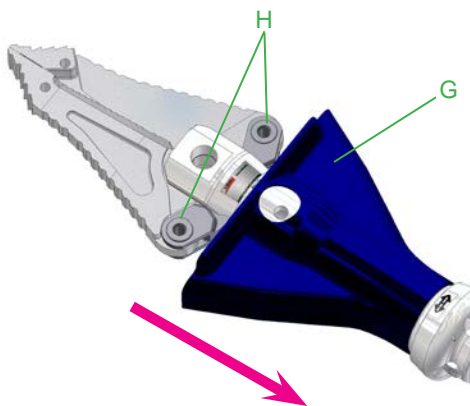

7. Remove retaining rings J.

8. Push bolts K out.

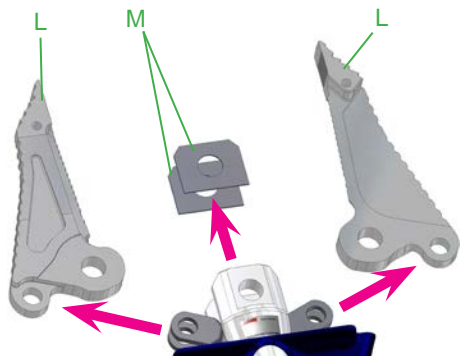
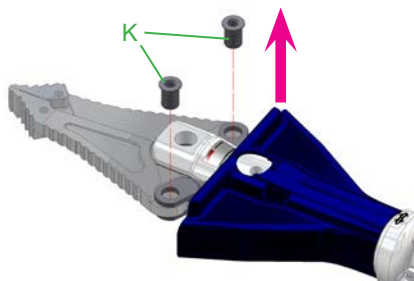

9. You can now remove blades L and sliding plates M.

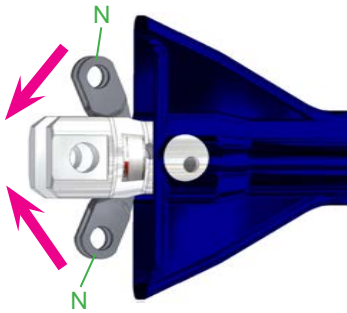

10. Fold in the lever elements N.

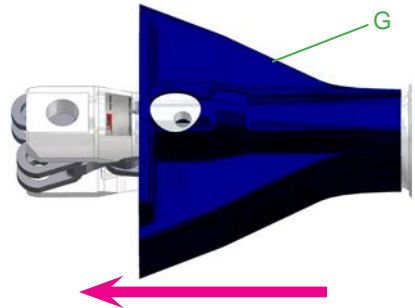

11. Finally, remove the hand guard G from the equipment as depicted.

12. In order to assemble the new parts, points 3-11 are to be carried out in reverse order.



CAUTION!

Don't forget to apply HURST special grease to all sliding surfaces.



REMARK:

If you only wish to change the blades, only carry out points 1, 2, 4, 5 as well as points 7, 8 and 9.

There is no need to dismantle the handle and reset the hand guard if you pull back / bend the front area of the hand guard such that you can reach the retaining rings and bolts.



CAUTION!

The nut of the pivot bolt and the pivot bolt itself will be adapt together by a special procedure, therefore they have only be changed as a set by usage of a new set! Because of the special procedure an unscrewing of the nut while working will be minimized and a resulting blade crack will be prevented.

The nuts can be unscrewed and thigtend up to 10 times without affecting the service performance!

10.3.5 Replacing the blade, protective cover and hand grip of the cutter S 312 and of the combi tool SC 358

<i>Components to be replaced</i>	<i>Required work steps</i>
Protective cover	1., 2. and 7.
Pivot bolt	1. - 4. and 7.
Handle	1. - 6. and 7.
Blade	1. - 5. and 7.

Work steps:

1. First of all, carefully clean the rescue equipment.

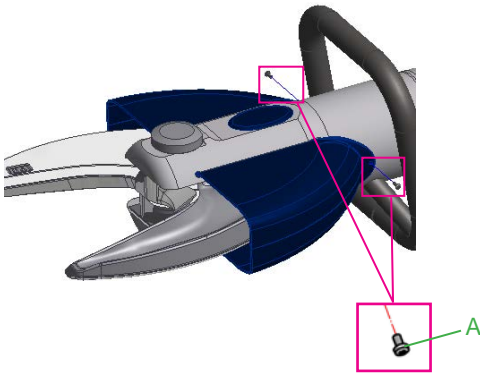

2. Remove the two fixing screws "A" and remove the protective cover "B". To do this, first pull the rounded rear edge outwards and then backwards through the hand grip, as the edges of the protective cover adjoining the cylinder body are kept in place by guide grooves. If necessary, loosen the hand grip and move it backwards to obtain sufficient space to pull it out.

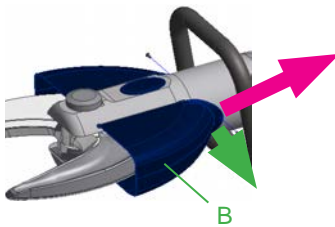

 **CAUTION / PLEASE NOTE!**
When operating the device with the hand guard removed, there is an increased risk of injury caused by the exposed, moving elements.

3. Move the blade arms on the until bolt "E" is easily accessible. Now switch off the device and remove the battery or unplug the power supply from the device.

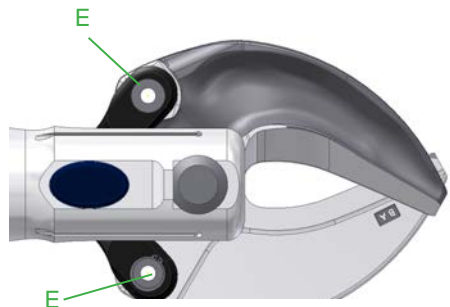

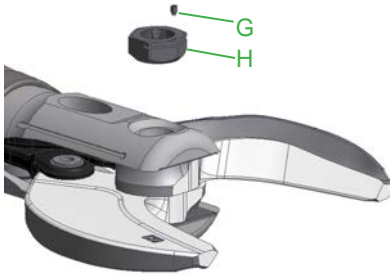

4. First remove the grub screw "G", then the central bolt nut "H" and then pull out the central pin "J".



5. Remove the locking rings "M" and push the pin "N" out. You can then pull out the blades "O" and the slide plates "P".

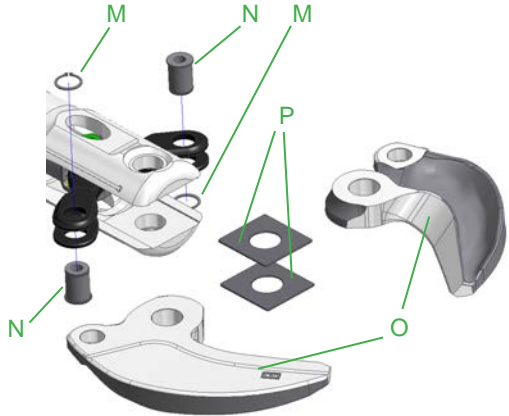

6. Release the fixing screws "K" and remove them. The handle "L" can now be pulled out forwards.

7. The work steps must be carried out in reverse order to fit the new parts.



ATTENTION!

Apply HURST special grease to all sliding surfaces!



NOTE:

The torque required can be taken from the spare parts list of your particular unit.

10.3.6 Changing or tightening hoses

Hoses of the pressure and/or return pipe leaks or hoses are defective. Tighten the hoses on the safety valve.

(Please note! Observe torque of $M_A = 40 \text{ Nm!}$)



REMARK when using mono-couplings:

If you want to change the hoses, you have to dismantle the mono-couplings.



CAUTION (by usage of mono-coupling-system)!

Take care that the port 'T' of the rescue tool is always connected to the port 'T' of the mono-coupling.



CAUTION (by usage of quick-disconnect-coupling-system)!

The return hose, which is screwed onto the port "T" of the rescue tool, must be equipped with a quick-disconnect-coupling (male) always. However the supplying hose line must be equipped with a quick-disconnect-coupling (female).

Procedure:

1. Loosen the 2 B screws in the handle sleeve with quick-disconnect protective sleeves C (hexagon socket)

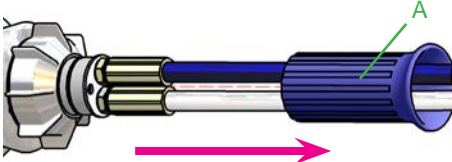

2. Remove handle sleeve A and tighten screwed connection. If necessary, renew seals.

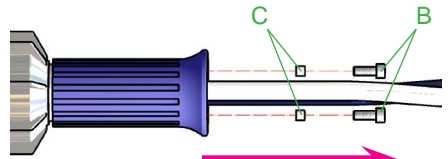

3. Dismantle hose D and sealing ring E. (There is no need to carry out this point if the hoses are just being tightened).

4. Screw the hose with sealing ring back on. Please ensure that the insulating washer F is on and correctly assembled.

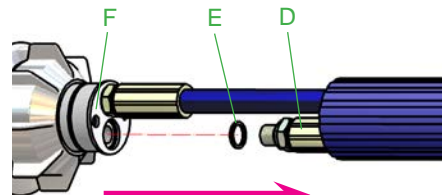

5. Tighten the hose connection on the safety valve.

(Please note! Observe the necessary torque of $M_A = 40 \text{ Nm!}$)

6. Then replace handle sleeve, protective sleeves and screws, tighten (Torque: 5Nm) and secure it with threadlocking fluid (e. g. LOCTITE 243).

10.3.7 Changing the handle (except S 120)

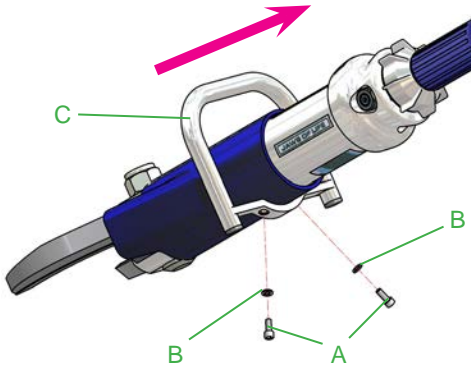

Remove screws A and spring washers B of handle C.

The handle can then be removed in the direction of the connecting hoses of the device.

10.3.8 Sharpening the blades

Only remove and smoothen any burrs!

Chips or deep grooves cannot be ground away. The blades must be replaced in these cases.

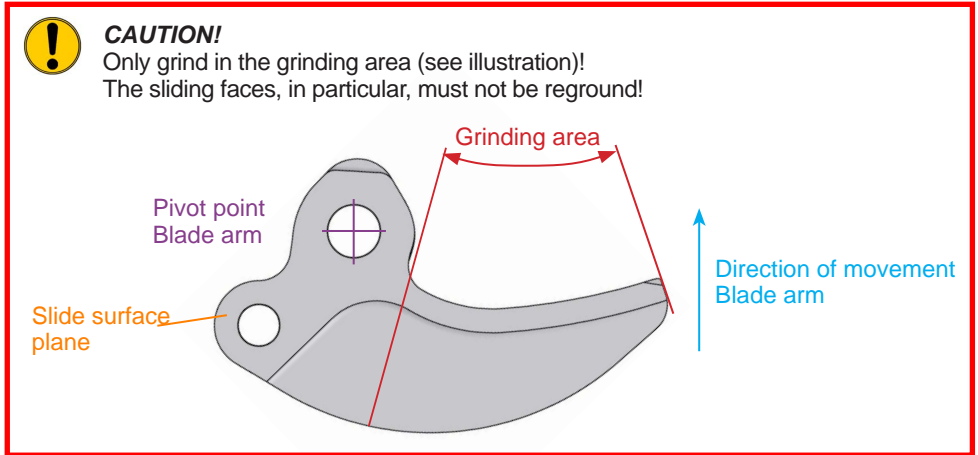

CAUTION!

Only grind in the grinding area (see illustration)!
The sliding faces, in particular, must not be reground!

Tools required:

1. Use jaw protection on clamping device (e.g. vice) in order not to damage the blades
2. Grinder (e.g. angle grinder or belt grinder) with abrasive having a grain size of 80.

Procedure:

1. Clamp the blade securely into the clamping device so that it cannot move, but with the grinding area exposed.
2. Carefully grind the burr away evenly until you reach the sliding surface level. (see illustration)



In addition, when grinding, you must make sure that the inclination of the cutting surface in the direction of the blade arm movement is not changed. Check the incline and smoothness of the ground surface, using a suitable measuring tool.



CAUTION!

If you have not maintained the smoothness or incline, the proper operation of the blade is no longer guaranteed and the blades must be replaced.

10.3.9 Mono-couplings

The mono-couplings must be replaced in the event of:

- external visible damage,
- the locking device not working,
- hydraulic fluid continually leaking in a coupled/uncoupled state.



WARNING / CAUTION!



Never repair couplings: they are to be replaced by original HURST parts!

During assembly, tighten the connection nut of the hose assembly with a torque of $M_A = 40 \text{ Nm}$.

Procedure:

1. Remove the kink-protection from the couplings.

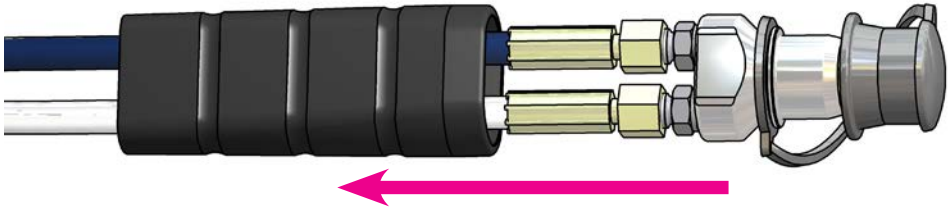

2. Loosen the connection nuts of the hose assembly and remove the coupling.

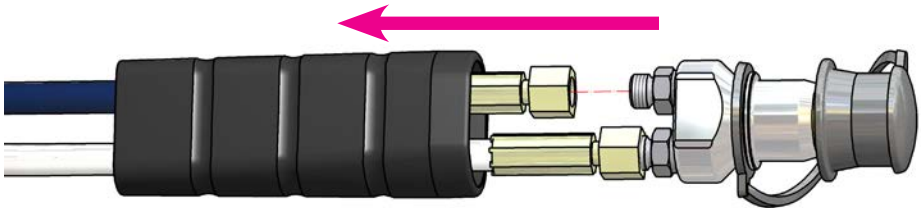

3. Position the new coupling and tighten the connection nuts of the hose assemblies with a torque of $M_A = 40 \text{ Nm}$ and push the kink-protection of the couplings back on.

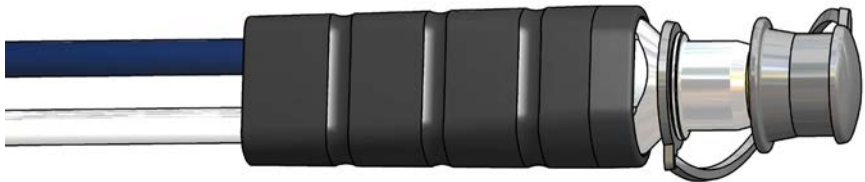

CAUTION!

Take care that the port 'T' of the rescue tool is always connected to the port 'T' of the mono-coupling.

10.3.10 Quick-disconnect-couplings

The quick-disconnect-couplings must be replaced in the event of:

- external visible damage,
- the locking device not working,
- hydraulic fluid continually leaking in a coupled/uncoupled state.



WARNING / CAUTION!



Never repair couplings: they are to be replaced by original HURST parts!

During assembly, tighten the connection nut of the hose assembly with a torque of $M_A = 35 \text{ Nm}$.

Procedure:

1. Loosen the connection nut of the hose assembly and remove the coupling.
2. Position the new coupling and tighten the connection nut of the hose assemblies with a torque of $M_A = 35 \text{ Nm}$.



CAUTION!

The return hose, which is screwed onto the port "T" of the rescue tool, must be equipped with a quick-disconnect-coupling (male) always.

However the supplying hose line must be equipped with a quick-disconnect-coupling (female).

10.3.11 Control valve

Should the safety valve be deformed so severely that the star grip no longer functions correctly, the valve must be replaced in its entirety.

Have repairs carried out by an authorised dealer, by personnel specially trained by HURST, or by HURST customer service only.

10.3.12 Labels

All damaged and/or illegible labels (safety notices, type plate, etc.) must be renewed.

Procedure:

1. Remove damaged and/or illegible labels.
2. Clean the surfaces using industrial alcohol.
3. Attach new labels.

Ensure that you attach the labels in the right position. If you are no longer sure about this, then please contact your authorised HURST dealer or HURST itself.

11. Troubleshooting

Trouble	Control	Cause	Solution
Blade arms move slowly or jerkily when activated	Are the hoses connected properly?	Air in the hydraulic system	Deaerate pump system
	Does the pump unit work?		
Device doesn't perform at its given power	Check the hydraulic fluid level in the supplying pump	Insufficient hydraulic fluid in the pump	Top up hydraulic fluid, deaerate
Following release, the star grip doesn't return to the central position	Cover damaged or star grip hard to move?	Damage to the torsion spring for reset	Repair by an authorised dealer, by personnel specially trained by HURST, or by HURST itself
		Soiled valve or star grip	
		Defective valve	
		Other mechanical damage (e. g. star grip)	
<u>with mono-coupling-system:</u> Hoses cannot be coupled		Pressure too high (e.g. caused by too-high ambient temperature)	Set hydraulic pump to pressureless circulation
		Coupling defective	Coupling needs to be replaced immediately
<u>with mono-coupling-system:</u> It is frequently not possible to couple hose assemblies	Control the degree of viscosity and application temperature of the used hydraulic fluid	Hydraulic fluid not adapted to the application situation	Hydraulic fluid must be replaced (see chapter "Recommended Hydraulic fluids")
		Coupling defective	Coupling needs to be replaced immediately
<u>with quick-disconnect-coupling-system:</u> Hoses cannot be coupled	Is the pump working?	Pressurized	Relieve pump
		Coupling defective	Coupling needs to be replaced immediately
Hydraulic fluid leak on the hoses or the fixing-ins	Are the hoses defective?	Leak, possible damage	Replace hoses
Damages on the surface of the hydraulic hoses		Mechanical damages or contact with aggressive agents	Replace hoses

Trouble	Control	Cause	Solution
Hydraulic fluid leaks on the piston rod		Defective rod seal	Repair by an authorised dealer, by personnel specially trained by HURST, or by HURST itself
		Damage to the piston	
Leak on the handhold	Increase load? (combi tool when spreading)	Load increase (e.g. something has fallen onto the part to be lifted, thereby suddenly increasing the load)	Secure the loads and move them by using other tools
			Move the load somewhere else, where the moving load is lighter
			Use supporting equipment to move the load.
	Does the pressure set on the pump comply with the maximum permissible pressure on the rescue equipment?	Pressure release in the Rescue tool.	Following the reduction in pressure, no further leak is present.
			Should, however, there be a further leak on the handhold, immediately deactivate the rescue equipment, and contact an authorised dealer or HURST itself.
	Hoses in handhold loose?	Hoses in handhold not tightened	Tighten hoses.
Check the connections of the mono-coupling (female)	Supply and return connection of the mono-coupling (female) inverted	Reconnect the hoses of the mono-coupling (female) in the right way	
<u>Especially by usage of quick-disconnect-couplings:</u> Leak on the handhold	Is the return hose connected correctly?	Return hose is not coupled correctly or not connected.	Re-connect the return hose and secure it.
<u>Especially by usage of mono-couplings:</u> Leak on the handhold	check the connections of the hoses	hose connection to the couplings interchanged	reconnect the hoses to the coupling in the right way
		Returnline disabled	disconnect the returnline from the coupling, clean it and reconnect it.
<u>with mono-coupling-system:</u> Leak in the couplings	Is the coupling damaged?	coupling damaged	Coupling must be replaced immediately

Trouble	Control	Cause	Solution
<i>with quick-disconnect-coupling-system:</i> Leak in the couplings	Is the coupling damaged?	coupling damaged	Coupling must be replaced immediately
	Is the leak only on the coupling male (in uncoupled status)?	Safety valve reacted	After pressure release there is no more leakage.

If it isn't possible to rectify the malfunctions, inform an authorised HURST dealer or the HURST customer service department immediately!

The address for the HURST customer service department is:

HURST Jaws of Life, INC

711 N. Post Road
 Shelby, NC 28150 USA
 Phone: (704) 487-6961
 Fax: (704) 487-7840

12. Technical Data

Since all values are subject to tolerances, minor differences may occur between the data on your equipment and the data in the following schedules!



NOTE:

The following tables contain only the technical data required for standard acceptance.

Additional data concerning your unit can be obtained from HURST on request.

12.1 Cutters

type	S 120	
ref. no.	212001000	272001000
dimensions l x w x h (w/o connection hoses)	[mm] <i>[in.]</i>	346 x 130 x 87 <i>13.6 x 5.1 x 3.4</i>
min. cutting opening	[mm] <i>[in.]</i>	53 <i>2.1</i>
max. cutting force (rear end of the cutting surface)	[kN] <i>[lbf.]</i>	183 <i>41140</i>
weight incl. hydraulic fluid	[kg] <i>[lbs.]</i>	4,3 <i>9.5</i>
max. operating pressure	[MPa] * <i>[psi.]</i>	70 <i>10000</i>
min. needed volume of hydraulic fluid	[cm ³] ** <i>[gal.-US]</i>	17 <i>0.005</i>
coupling system	quick-disconnect-coupling	mono-coupling
classification acc. to NFPA 1936	A4/B3/C2/D3/E3	

* 1 MPa = 10 bar

** Necessary volume of hydraulic fluid in the hydraulic unit to operate the unit (differential volume on piston / rod side)

type		S 312
ref. no.		272021000
dimensions l x w x h (w/o connection hoses)	[mm] <i>[in.]</i>	723 x 228 x 172 <i>28.5 x 9.0 x 6.8</i>
min. cutting opening	[mm] <i>[in.]</i>	162 <i>6.4</i>
max. cutting force (rear end of the cutting surface)	[kN] <i>[lbf.]</i>	680 <i>152900</i>
weight incl. hydraulic fluid	[kg] <i>[lbs.]</i>	14.5 <i>32.0</i>
max. operating pressure	[MPa] * <i>[psi.]</i>	70 <i>10000</i>
min. needed volume of hydraulic fluid	[cm ³] ** <i>[gal.-US]</i>	110 <i>0.029</i>
coupling system		mono-coupling
classification acc. to NFPA 1936		A7/B8/C7/D7/E7

* 1 MPa = 10 bar

** Necessary volume of hydraulic fluid in the hydraulic unit to operate the unit (differential volume on piston / rod side)

type		S 330	
ref. no.		212030000	272030000
dimensions l x w x h (w/o connection hoses)	[mm] <i>[in.]</i>	726 x 211 x 163 <i>28.6 x 8.3 x 6.4</i>	
min. cutting opening	[mm] <i>[in.]</i>	228 <i>9.0</i>	
max. cutting force (rear end of the cutting surface)	[kN] <i>[lbf.]</i>	616 <i>138482</i>	
weight incl. hydraulic fluid	[kg] <i>[lbs.]</i>	14,8 <i>32.7</i>	
max. operating pressure	[MPa] * <i>[psi.]</i>	70 <i>10000</i>	
min. needed volume of hydraulic fluid	[cm ³] ** <i>[gal.-US]</i>	98 <i>0.026</i>	
coupling system		quick-disconnect-coupling	mono-coupling
classification acc. to NFPA 1936	A7/B7/C7/D8/E8		

* 1 MPa = 10 bar

** Necessary volume of hydraulic fluid in the hydraulic unit to operate the unit (differential volume on piston / rod side)

type		S 510	
ref. no.		212040000	272040000
dimensions l x w x h (w/o connection hoses)	[mm] <i>[in.]</i>	776 x 240 x 170 <i>30.6 x 9.45 x 6.69</i>	
min. cutting opening	[mm] <i>[in.]</i>	202 <i>7.9</i>	
max. cutting force (rear end of the cutting surface)	[kN] <i>[lbf.]</i>	962 <i>216266</i>	
weight incl. hydraulic fluid	[kg] <i>[lbs.]</i>	18,9 <i>41.7</i>	
max. operating pressure	[MPa] * <i>[psi.]</i>	70 <i>10000</i>	
min. needed volume of hydraulic fluid	[cm ³] ** <i>[gal.-US]</i>	150 <i>0.04</i>	
coupling system		quick-disconnect-coupling	mono-coupling
classification acc. to NFPA 1936		A8/B9/C7/D8/E9	

* 1 MPa = 10 bar

** Necessary volume of hydraulic fluid in the hydraulic unit to operate the unit (differential volume on piston / rod side)

type		S 511	
ref.no.		212050000	272050000
dimensions l x w x h (w/o connection hoses)	[mm] <i>[in.]</i>	746 x 245 x 170 <i>29.4 x 9.65 x 6.69</i>	
min. cutting opening	[mm] <i>[in.]</i>	162 <i>6.4</i>	
max. cutting force (rear end of the cutting surface)	[kN] <i>[lbf.]</i>	1194 <i>268422</i>	
weight incl. hydraulic fluid	[kg] <i>[lbs.]</i>	18,7 <i>41.3</i>	
max. operating pressure	[MPa] * <i>[psi.]</i>	70 <i>10000</i>	
min. needed volume of hydraulic fluid	[cm ³] ** <i>[gal.-US]</i>	150 <i>0.04</i>	
coupling system		quick-disconnect-coupling	mono-coupling
classification acc. to NFPA 1936	A8/B8/C7/D8/E9		

* 1 MPa = 10 bar

** Necessary volume of hydraulic fluid in the hydraulic unit to operate the unit (differential volume on piston / rod side)

type		S 530	
ref.no.		212060000	272060000
dimensions l x w x h (w/o connection hoses)	[mm] <i>[in.]</i>	780 x 245 x 170 <i>30.7 x 9.65 x 6.69</i>	
min. cutting opening	[mm] <i>[in.]</i>	297 <i>11.7</i>	
max. cutting force (rear end of the cutting surface)	[kN] <i>[lbf.]</i>	1015 <i>228181</i>	
weight incl. hydraulic fluid	[kg] <i>[lbs.]</i>	18,1 <i>40</i>	
max. operating pressure	[MPa] * <i>[psi.]</i>	70 <i>10000</i>	
min. needed volume of hydraulic fluid	[cm ³] ** <i>[gal.-US]</i>	150 <i>0.04</i>	
coupling system		quick-disconnect-coupling	mono-coupling
classification acc. to NFPA 1936		A8/B7/C7/D8/E9	

* 1 MPa = 10 bar

** Necessary volume of hydraulic fluid in the hydraulic unit to operate the unit (differential volume on piston / rod side)

type		S 700	
ref.no.		212081000	272081000
dimensions l x w x h (w/o connection hoses)	[mm] <i>[in.]</i>	790 x 300 x 258 <i>31.1 x 11.8 x 10.2</i>	
min. cutting opening	[mm] <i>[in.]</i>	185 <i>7.28</i>	
weight incl. hydraulic fluid	[kg] <i>[lbs.]</i>	21,3 <i>47.0</i>	
max. operating pressure	[MPa] * <i>[psi.]</i>	70 <i>10000</i>	
min. needed volume of hydraulic fluid	[cm ³] ** <i>[gal.-US]</i>	325 <i>0.09</i>	
coupling system		quick-disconnect coupling	mono-coupling
classification acc. to NFPA 1936		A8/B9/C8/D9/E9	

* 1 MPa = 10 bar

** Necessary volume of hydraulic fluid in the hydraulic unit to operate the unit (differential volume on piston / rod side)

12.2 Combi tools

type		SC 358
ref.no.		27303800
dimensions l x w x h (w/o connection hoses)	[mm] <i>[in.]</i>	774 x 228 x 172 <i>30.5 x 9.0 x 6.8</i>
min. cutting opening	[mm] <i>[in.]</i>	309 <i>12.2</i>
max. cutting force (rear end of the cutting surface)	[kN] <i>[lbf.]</i>	492 <i>110600</i>
max. spreading distance (on the blade tips)	[mm] <i>[in.]</i>	372 <i>14.7</i>
min. spreading force (25mm from the tips)	[kN] <i>[lbf.]</i>	38 <i>8543</i>
spreading force HSF (according to NFPA)	[kN] <i>[lbf.]</i>	43 <i>9667</i>
spreading force LSF (according to NFPA)	[kN] <i>[lbf.]</i>	33 <i>7419</i>
pulling force HPF (according to NFPA)	[kN] <i>[lbf.]</i>	62 <i>13940</i>
pulling force LPF (according to NFPA)	[kN] <i>[lbf.]</i>	43 <i>9667</i>
weight incl. hydraulic fluid	[kg] <i>[lbs.]</i>	14,8 <i>32.6</i>
max. operating pressure	[MPa] * <i>[psi.]</i>	70 <i>10000</i>
min. needed volume of hydraulic fluid	[cm ³] ** <i>[gal.-US]</i>	110 <i>0.029</i>
coupling system		mono-coupling
classification acc. to NFPA 1936		A7/B7/C7/D8/E7

* 1 MPa = 10 bar

** Necessary volume of hydraulic fluid in the hydraulic unit to operate the unit (differential volume on piston / rod side)

type		SC 557	
ref.no.		213047000	273047000
dimensions l x w x h (w/o connection hoses)	[mm] <i>[in.]</i>	840 x 295 x 190 <i>33.1 x 11.6 x 7.48</i>	
min. cutting opening	[mm] <i>[in.]</i>	355 <i>14</i>	
max. cutting force (rear end of the cutting surface)	[kN] <i>[lbf.]</i>	810 <i>182095</i>	
max. spreading distance (on the blade tips)	[mm] <i>[in.]</i>	430 <i>16.9</i>	
min. spreading force (25 mm from the tips)	[kN] <i>[lbf.]</i>	41,5 <i>9330</i>	
spreading force HSF (according to NFPA)	[kN] <i>[lbf.]</i>	47 <i>10566</i>	
spreading force LSF (according to NFPA)	[kN] <i>[lbf.]</i>	39 <i>8767</i>	
pulling force HPF (according to NFPA)	[kN] <i>[lbf.]</i>	67 <i>15062</i>	
pulling force LPF (according to NFPA)	[kN] <i>[lbf.]</i>	52 <i>11690</i>	
weight incl. hydraulic fluid	[kg] <i>[lbs.]</i>	19,8 <i>43.7</i>	
max. operating pressure	[MPa] * <i>[psi.]</i>	70 <i>10000</i>	
min. needed volume of hydraulic fluid	[cm³] ** <i>[gal. -US]</i>	108 <i>0.029</i>	
coupling system		quick-disconnect- coupling	mono-coupling
classification acc. to NFPA 1936		A8/B9/C8/D9/E9	

* 1 MPa = 10 bar

** Necessary volume of hydraulic fluid in the hydraulic unit to operate the unit
(differential volume on piston / rod side)

12.3 Torque of the pivot bolt

type	pivot bolt	wrench size	torque
		[mm] <i>[in.]</i>	[Nm] <i>[lbf.in.]</i>
S 120	M 22 x 1,5	34 <i>1.34</i>	80 + 10 <i>708 + 89</i>
S 312	M 28 x 1,5	38 <i>1.50</i>	130 + 10 <i>1151 + 89</i>
S 330	M 24 x 1,5	36 <i>1.42</i>	120 + 10 <i>1062 + 89</i>
S 510	M 27 x 1,5	41 <i>1.61</i>	130 + 10 <i>1151 + 89</i>
S 511			
S 530			
S 700	M 32 x 1,5	46 <i>1.81</i>	150 + 10 <i>1328 + 89</i>
SC 358	M 28 x 1,5	38 <i>1.50</i>	130 + 10 <i>1151 + 89</i>
SC 557	M 27 x 1,5	41 <i>1.61</i>	130 + 10 <i>1151 + 89</i>

12.4 Cutting performance

Device type	Max. cutting material dimensions				
	Round material [mm] <i>[in.]</i>	Flat material [mm] <i>[in.]</i>	Round tube [mm] <i>[in.]</i>	Square tube [mm] <i>[in.]</i>	Rectangular tube [mm] <i>[in.]</i>
S 120	22 <i>0.9</i>	50x5 <i>1.97x0.2</i>	26,4x2,3 <i>1.04x0.09</i>		
S 312	35 <i>1.38</i>	120x10 <i>4.72x0.39</i>	88,9x4,0 <i>3.5x0.16</i>	70x4 <i>2.75x0.16</i>	100x50x4,0 <i>3.94x1.97x0.16</i>
S 330	33 <i>1.30</i>	120x10 <i>4.72x0.39</i>	88,9x4,0 <i>3.5x0.16</i>	70x4 <i>2.75x0.16</i>	100x50x4,0 <i>3.94x1.97x0.16</i>
S 510	39 <i>1.5</i>	140x10 <i>5.51x0.39</i>	88,9x4,0 <i>3.5x0.16</i>	70x4 <i>2.75x0.16</i>	100x50x4,0 <i>3.94x1.97x0.16</i>
S 511	43 <i>1.7</i>	130x10 <i>5.12x0.39</i>	88,9x4,0 <i>3.5x0.16</i>	70x4 <i>2.75x0.16</i>	100x50x5,0 <i>3.94x1.97x0.20</i>
S 530	40 <i>1.57</i>	120x10 <i>4.72x0.39</i>	88,9x5,0 <i>3.5x0.20</i>	70x5 <i>2.75x0.20</i>	100x50x5,0 <i>3.94x1.97x0.20</i>
S 700	38 <i>1.49</i>	140x10 <i>5.51x0.39</i>	101,6x4,0 <i>4.0x0.16</i>	70x5 <i>2.75x0.20</i>	100x50x5,0 <i>3.94x1.97x0.20</i>
SC 358	35 <i>1.38</i>	130x10 <i>5.12x0.39</i>	88,9x4,0 <i>3.5x0.16</i>	70x4 <i>2.75x0.16</i>	100x50x4,0 <i>3.94x1.97x0.16</i>
SC 557	38 <i>1.49</i>	140x10 <i>5.51x0.39</i>	101,6x4,0 <i>4.0x0.16</i>	70x5 <i>2.75x0.20</i>	100x50x5,0 <i>3.94x1.97x0.20</i>

The tensile strength of all materials meets the testing criteria of NFPA 1936.

12.5 Recommended hydraulic fluid

Hydraulic fluid for HURST hydraulic equipment:

Mineral oil DIN ISO 6743-4 and others

	Oil temperature range	Oil code	Viscosity rating	Remarks
A	-20 +55°C -4.0 +131°F	HM 10	VG 10	

recommended viscosity range: 10...200 mm²/s (10...200 cSt.)

Supplied with HM 10 DIN ISO 6743-4.



CAUTION!

Before using hydraulic fluids, which do not correspond to the above-mentioned specifications and/or are not purchased from HURST, you have to contact HURST itself!

12.6 Operating and storage temperature ranges

Operating temperature	[°C] / [°F]	-20 ... +55	-4 ... +131
Storage temperature (device not in operation)	[°C] / [°F]	-30 ... +60	-22 ... +140

13. Notes



Please dispose all packaging materials and dismantled parts properly.

HURST JAWS OF LIFE, INC

A Unit of IDEX Corporation

711 N. Post Road
Shelby, NC 28150 USA
Phone: (704) 487-6961
Fax: (704) 487-7271
e-mail: contacthurst@idexcorp.com
www.jawsoflife.com

MADE IN USA