

Instruction manual for rescue equipment

Hydraulic power unit ML-630-SI

STREAMLINE
TECHNOLOGY



375070085 EN
Edition 02.2015
replaces 11.2014

Content	Page
1. Danger classifications	5
2. Product safety	6
3. Proper use	10
4. Power unit designation	11
5. Functional description	11
5.1 <i>General information</i>	11
5.2 <i>Installation of the power unit</i>	12
5.3 <i>Motor</i>	13
5.4 <i>Valves</i>	14
5.5 <i>Pumps</i>	15
5.6 <i>Frame with side sections</i>	15
5.7 <i>Connection to the rescue equipment</i>	15
6. Connecting the hoses / devices	16
7. Set-up and start-up	18
7.1 <i>Set-up</i>	18
7.2 <i>Start-up</i>	18
8. Operation	20
8.1 <i>Starting the engine</i>	20
8.2 <i>Turning the engine off</i>	21
8.3 <i>Refuelling</i>	21
8.4 <i>Controlling the valves</i>	22
9. Dismantling the equipment / deactivation following operation	23
10. Tests	24
10.1 <i>Recommended test intervals</i>	24
10.2 <i>Visual and function check</i>	25
11. Maintenance and repair	26
11.1 <i>General information</i>	26
11.2 <i>Service work on the hydraulic unit</i>	27
11.3 <i>Additional service work</i>	29
12. Fault analysis	34



Content

Page

13. Technical data	39
13.1 <i>Power unit</i>	39
13.2 <i>Noise emissions</i>	41
13.3 <i>Sparking plug</i>	42
13.4 <i>Sparking plug spanner</i>	42
13.5 <i>Fuel</i>	42
13.6 <i>Engine oil</i>	43
13.7 <i>Hydraulic fluid recommendation</i>	43
13.8 <i>Operating and storage temperature range</i>	43
14. EC Declaration of Conformity	44
15. Notes	45

1. Danger classifications

We differentiate between various different categories of safety instructions. The table shown below shows you an overview of the assignment of symbols (pictograms) and signal words to the specific danger and the possible consequences.

Pictogram	Damage / injury to	Key word	Definition	Consequences
	Persons	DANGER!	Immediate danger	Death or severe injury
		WARNING!	Potentially dangerous situation	Potential death or serious injury
		CAUTION!	Less dangerous situation	Minor or slight injury
	Property	ATTENTION!	Danger of damage to property/ environment	Damage to the equipment, damage to the environment, damage to surroundings
	-	NOTE	Handling tips and other important/ useful information and advice	No injury/damage to persons/ environment/ device



Wear a helmet with a face guard



Wear protective gloves



Wear safety shoes



Proper recycling



Protect the environment



Read and follow operating instructions

2. Product safety

HURST products are developed and manufactured to ensure the best performance and quality when used as intended.

The safety of the operator is the most important consideration in product design. Furthermore, the operating instructions are intended to help in using HURST products safely.

The generally applicable legal and other binding regulations pertaining to the prevention of accidents and protection of the environment apply and are to be complied with in addition to the operating instructions.

The equipment must only be operated by persons with appropriate training in the safety aspects of such equipment – otherwise, there is a danger of injury.

We would like to point out to all users that they should read carefully the operating instructions and the instructions contained therein before they use the equipment, and that they should carefully follow such.

We further recommend you have a qualified trainer show you how to use the product.



CAUTION!

The operating instructions for the hoses, accessories and the connected devices must also be heeded!

























Even if you have already received instruction on how to use the equipment, you should still read through the following safety instructions again.

















CAUTION!

Ensure that the accessories and connected equipment are suitable for the maximum operating pressure!

	<p>Please ensure that no body parts or clothing get stuck between the visibly moving parts.</p>	<p>Immediately report any changes that occur (including changes in operating behaviour) to the appropriate persons/ departments! If necessary, the equipment is to be shut down immediately and secured!</p>	
	<p>Wear protective clothing, safety helmet with visor, safety shoes and protective gloves.</p>	<p>Check the equipment for visible flaws or damage before and after use.</p>	
 	<p>Working under suspended loads is not permitted where such loads are being lifted only by means of hydraulic devices. If this work is unavoidable, suitable mechanical supports are also required.</p>	<p>Check all lines, hoses and screwed connections for leaks and externally visible damage, and repair immediately! Escaping hydraulic fluid can cause injuries and fires.</p>	

	<p>In the event of malfunctions, immediately deactivate the device and secure it. Repair the fault immediately.</p>	<p>Do not carry out any changes (additions or conversions) to the equipment without obtaining the approval of HURST beforehand.</p>	
 	<p>Observe all safety and danger information on the device and in the operating instructions.</p>	<p>All safety and danger information on the device must always be complete and in a legible condition.</p>	
 	<p>Please ensure that all safety covers are present on the equipment and that they are in proper and adequate condition.</p>	<p>Any mode of operation which compromises the safety and/or stability of the device is forbidden!</p>	 
 	<p>Safety devices must never be disabled!</p>	<p>The maximum operating pressure set on the equipment must not be changed!</p>	
	<p>Make sure before switching on/starting up the device and during its operation, that this will put no one in danger.</p>	<p>Observe all intervals for recurring tests and/or inspections that are prescribed or stated in the operating instructions.</p>	
 	<p>When working close to live components and cables, suitable measures must be taken to avoid current transfers or high-voltage transfers to the equipment.</p>	<p>Only original HURST accessories and spare parts are to be used for repairs.</p> <p>When working with this equipment or when transporting it, ensure that you do not get caught up in the hose or cable loops and trip.</p>	 
 	<p>The build-up of static charge and therefore possible sparking must be avoided when handling the device.</p>	<p>Do not touch the engine and exhaust system when running with combustion engine pumps because of the danger of burning.</p>	
 	<p>Motorised pumps must not be operated in areas at risk of explosion!</p>	<p>Combustion engines must not be operated in enclosed spaces because of the danger of poisoning and / or smothering.</p>	

	<p>If you spill any fuel when using combustion engines, you must remove the spilled fuel completely before starting the engine.</p>	<p>Refuelling whilst the engine is running is strictly prohibited!</p>	
	<p>Keep combustion engines and their fuels away from sources of ignition since otherwise there will be a danger of explosion.</p>	<p>All damaged electrical components e.g. scorched cables, etc. are to be replaced immediately!</p>	
	<p>In order to prevent the danger of fire, you should ensure adequate ventilation when operating combustion engines and you must keep a safety distance of at least 1m (39.4 in.) to walls and other screens.</p>	<p>Damage to electrical components must only be repaired by a qualified electrician in compliance with all applicable national and international safety guidelines and regulations.</p>	
	<p>Make sure that the combustion engines are always standing on as flat and horizontal a surface as possible to prevent fuel from leaking out.</p>	<p>When setting up the units, you must make sure that they are not impaired by the influences of extreme temperatures.</p>	
 	<p>The equipment is filled with hydraulic fluid. This hydraulic fluid can be detrimental to health if it is swallowed or its vapour is inhaled. Direct contact with the skin must be avoided for the same reason. Also, when handling hydraulic fluid, note that it can negatively affect biological systems.</p>	<p>When working with or storing the equipment, ensure that the function and the safety of the equipment are not impaired by the effects of severe external temperatures or that the equipment is damaged in any way. Please note that the equipment can also heat up over a long period of use.</p>	
	<p>Make sure there is adequate lighting while working.</p>	<p>Before transporting the equipment, always ensure that the accessories are positioned in such a way that they cannot cause an accident.</p>	
	<p>Always keep these operating instructions easily accessible at the place of operation.</p>	<p>Ensure the proper disposal of all removed parts, leftover oil, hydraulic fluid and packaging materials.</p>	

The generally applicable, legal and other binding national and international regulations pertaining to the prevention of accidents and protection of the environment apply and are to be implemented in addition to the operating instructions.

WARNING/CAUTION!

The device is **intended exclusively for the purpose stated in the operating instructions (see chapter "Proper Use")**. Any other use is not in accordance with its designated use. The manufacturer/supplier is not liable for any damages resulting from improper use. The user bears sole responsibility for such use. Proper use includes observance of the operating instructions and compliance with the inspection and maintenance conditions.



Never work in a fatigued or intoxicated state!



WARNING/CAUTION!

If you still injure yourself on the hydraulic unit, clean the wound immediately and consult a doctor to have it attended to!



If you get hydraulic fluid in your eye, rinse it immediately several times with clear, clean water and consult a doctor!

Also, if you swallow hydraulic fluid you should consult a doctor!

3. Proper use

HURST hydraulic units are specially designed to supply HURST rescue equipment with hydraulic fluid so that this equipment can be used to rescue victims of road, rail or air traffic accidents as well as from buildings.

Their use for supplying pressure / fluid to rescue equipment of other manufacturers is possible, yet requires the technical inspection and approval by HURST in each individual case.



CAUTION!

The ML-630 power units were not developed for being operated without hoses or devices (operating time < 15 minutes).



WARNING/CAUTION!

The safety instructions in this operating instruction manual concerning the site of erection and type of erection must always be observed!



HURST ML-630 units are not explosion protected!

When using the equipment in explosion-risk areas you must make sure that operation of the unit does not trigger an explosion!

The responsibility for explosion prevention or for ruling out work with the ML-630 rests with the operator of the device or with the person responsible at the place of use.

When working in areas at risk of explosion, all applicable legal, national and international regulations, standards and safety rules for avoiding explosions must be observed without limitation!

The equipment should not come into contact with acids or alkalis. If this is unavoidable, clean the equipment immediately afterwards with a suitable cleaning agent.

You can obtain accessories and replacement parts for the rescue apparatus from your authorised HURST dealer!



ATTENTION!

When selecting the units to connect to the unit, bear in mind that the maximum possible useable volume of hydraulic fluid is limited.

The sum of the max. required operating volume (hydraulic fluid) of all connected equipment must not exceed the maximum possible usable volume of the power unit!



NOTE:

Always register your hydraulic unit on the HURST Jaws of Life internet site. This is the only way to guarantee your extended warranty cover.

Before you use couplings from a different company, you must contact HURST or an authorised dealer.

4. Power unit designation

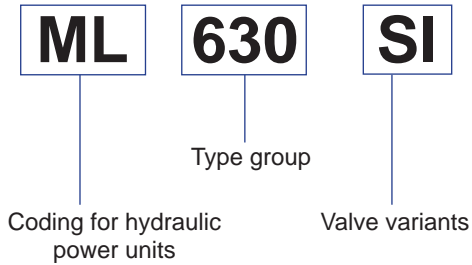

Valve variant:

SI = Simultaneous operation

5. Functional description

5.1 General information

In the case of all HURST hydraulic power units, the hydraulic pump is operated with a motor. The pump conveys the fluid from the hydraulic oil tank and builds up the pressure in the tool. Fluid is distributed to the connected equipment through control valves. The ML-630-SI is a power unit with frame and with a gasoline engine and simultaneous operation.

5.2 Installation of the power unit

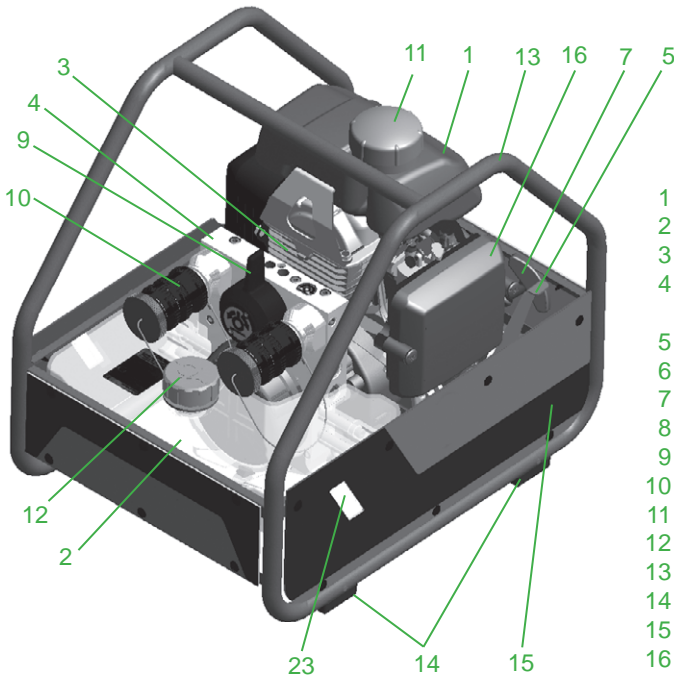

- 1 Gasoline tank
- 2 Hydraulic fluid tank
- 3 Engine with hydraulic pump
- 4 Connecting block with control valves
- 5 Speed adjusting lever
- 6 Carrying handle
- 7 Cable-pull starter
- 8 Valve control lever
- 9 "TURBO" control lever
- 10 Mono-coupling (female)
- 11 Fuel tank cap
- 12 Filler cap hydraulic fluid
- 13 Frame
- 14 Rubber buffer
- 15 Side panel
- 16 Air filter
- 17 Choke
- 18 Fuel tap
- 19 ON/OFF switch (engine switch)
- 22 Engine oil filler cap/dipstick
- 23 Fill level indicator

Equipment back

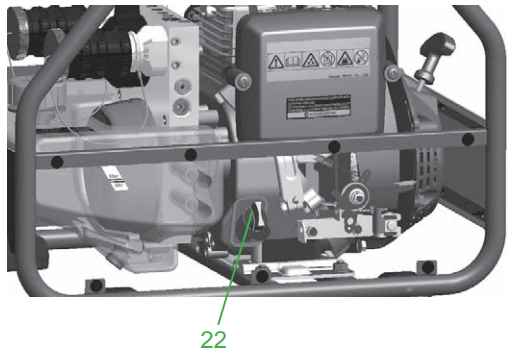
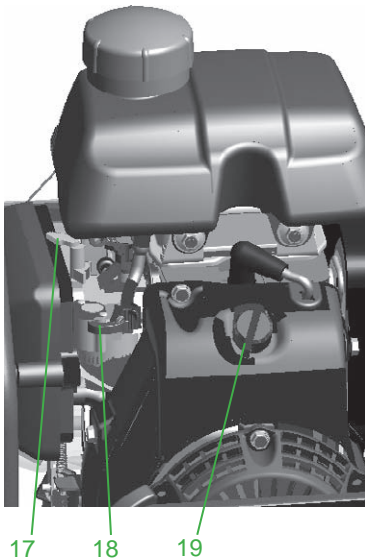

5.3 Motor



WARNING/CAUTION!

See also the separate operating instructions of each engine manufacturer accompanying the delivery.

5.3.1 Gasoline engine

These hydraulic units are equipped with a combustion engine driven by the fuel "gasoline". The power units are equipped with a cable-pull starter with which the engine is started. *(For specific details, please consult the separate operating instructions of the engine manufacturer!)*

HONDA motors have a main switch that must be activated to switch the power unit on and off. The speed adjusting lever on these power units has two switch positions.

Switch position 1 (standard): Speed 3000 1/min "🐢" and

Switch position 2: Speed 3800 1/min "🐇".

The setting is adjusted by moving the speed adjusting lever.



NOTE:

The engine installed in the HURST power units does not match every detail of the engine described in the manufacturer's separate operating instructions. Nevertheless, it is important that you follow all safety rules and operating, maintenance and storage instructions in the separate engine instructions as absolute since they are not affected by adjustments made by HURST.

5.4 Valves

Both valves of the power unit in the pump block are fixed in place. The pump block is fully integrated into the hydraulic power unit. The hose assemblies (pressure line (grey) and return (blue)) must be connected to the pump block. The rescue equipment is connected to the hose assemblies. Model ML-630 units are equipped with a SIMO connecting block.

The connecting block of the ML-630-SI also has a TURBO function.

With a switching lever, either both connected devices can be supplied simultaneously with hydraulic fluid, or a single device can be supplied with double the volume (= TURBO function). By supplying at double the feed rate, the speed of the connected device is increased.

The hoses are connected with the connecting block via mono-couplings.

5.4.1 Control valve "simultaneous operation" (SIMO)

This valve enables the connection of two pressure hoses and two return hoses. It has two switching options, each of which controls the pressure application of the pressure hose that is marked accordingly. This means that **two devices can be supplied with pressure simultaneously and independently of each other**. Without impairing the work output, it enables work with two devices simultaneously and independently of each other.



ATTENTION!

When operating several pieces of rescue equipment with one unit, ensure that the usable volume of hydraulic fluid in the power unit is greater than the maximum possible operating fluid volume of all connected rescue equipment.

5.5 Pumps

The HURST hydraulic power units model ML-630 are equipped with a SIMO connecting block. The pump is rigidly connected to the connecting block.

Double-flow pump for operating with SIMO valve

The pump used always has two pressure stages per pump feed flow, one low pressure and one high pressure.

Low-pressure level (LP) = up to 14 MPa*

High-pressure level (HP) = up to 50 MPa*

*) 1 MPa = 10 bar)

The changeover from low pressure to high pressure is carried out automatically by the pump. This system is secured with a pressure limiting valve. Therefore, the maximum permissible system pressure cannot be exceeded.



WARNING/CAUTION!



For safety reasons, the pressure set on this valve must **not** be adjusted (without the approval of HURST directly)!

5.6 Frame with side sections

The ML-630 hydraulic power unit is mounted within a frame.

The frame and side panels are also used, despite the robust design, to protect the power unit from external influences, such as for example, dirt or damage.

5.7 Connection to the rescue equipment

Connection to the rescue equipment is via extension hose pairs or via hose reels. They are supplied in various lengths.

(For specific details, please consult the HURST range of accessories or contact your HURST dealer.)

6. Connecting the hoses / devices



ATTENTION!

When connecting the hose assemblies / units, always ensure that the connection components are not dirty. Clean prior to use if necessary!



WARNING/CAUTION!

Before connecting the equipment, make sure that **all the components used are suitable for the maximum operating pressure of the hydraulic unit!** In cases of doubt, **you must consult HURST** directly before connecting the equipment!



Coupling the mono-couplings

The hose lines / units are connected via quick-disconnect coupling halves (female and male) to the hydraulic pump or hose reel in such a way that they cannot be swapped over.

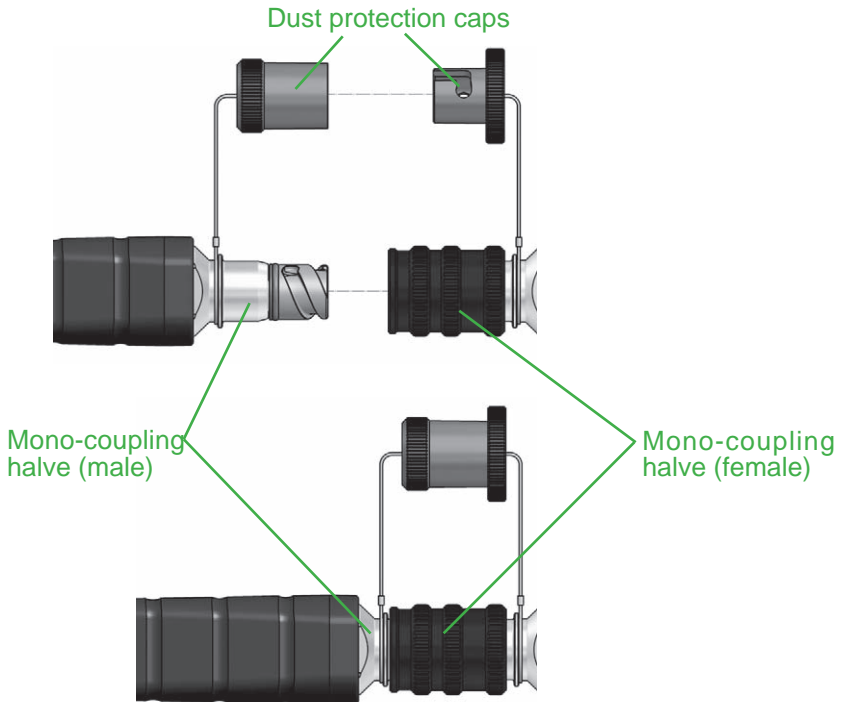

Remove the dust caps before coupling together. Then push the male and female parts together and turn the locking sleeve on the female coupling in the direction "1" until the locking sleeve clicks in place. The connection has been made and locked. Decoupling is accomplished by turning the locking sleeve in direction "0".

Coupling of the hose assemblies when under pressure is also possible, assuming that the connected equipment is not turned on.



NOTE:

We **recommend** connecting the coupling halves in a **depressurised** state when working in areas with low ambient temperature and using extension hose assemblies / hose reels, as otherwise the coupling may require the application of a great deal of force.

For dust protection, the supplied dust caps must be refitted.

Using the dust protection caps:

The dust protection caps "A" have two external grooves "B". The dust protection caps must be inserted in the female coupling in such a way that the grooves can be guided over the pins "C". Screw in the dust protection caps to the stop to fix in the female couplings.

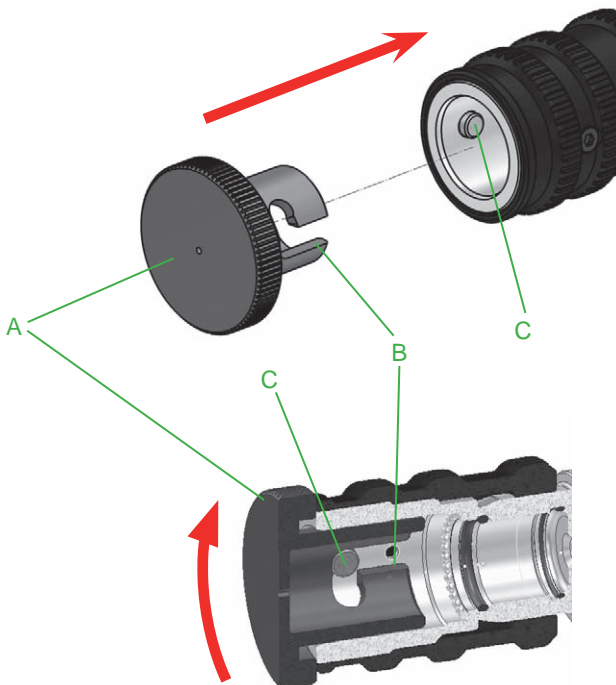

7. Set-up and start-up

7.1 Set-up



WARNING/CAUTION!

Because of possible spark formation, combustion engine units and electrical equipment cannot be used in an explosion-risk area. Units with combustion engines must not be used in enclosed spaces, as there is a danger of poisoning and/or asphyxiation!



The unit is to be set up in a suitable location (secure location / flat surface / sufficient distance from vehicles, loads, sources of ignition, etc.).

HURST units work perfectly at an angle of up to 20°. However, in order to guarantee maximum safety and fluid withdrawal, they should be operated in as horizontal a position as possible.

7.2 Start-up



NOTE:

The engine oil level must be inspected before the first commissioning or after longer periods of storage. First fill the engine or top up the engine oil!
For safety reasons, HURST power units do not contain engine oil upon delivery!



ATTENTION!

Never mix up the fuel and hydraulic fluid tanks when filling the tank; this can damage the power unit!

7.2.1 First commissioning - Power unit without engine oil, hydraulic fluid and gasoline.

1. Pour in the engine oil according to the instructions in the scope of delivery included with the separate manufacturer operating instructions regarding the filler opening (engine oil filler cap, see chapter "Installation of the power unit").
2. Pour hydraulic oil into the hydraulic fluid tank until the fill level indicator in the viewing window is between MIN/MAX (see illustration on the right). The upper mark shows the absolute fill level when connecting additional equipment with increased usable volume. The resulting fill quantity is up to 3.0 l.
3. Pour fuel (gasoline) into the tank until the fill level is just below the filler opening. If the power unit is resting on an inclined surface, do not fill the tank to its maximum capacity.

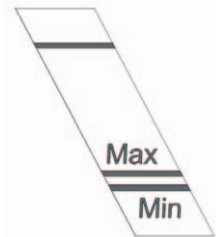

Hydraulic oil fill level indicator

4. Now bleed the hydraulic power unit:
5. Set all levers of the distributor valve to circulation at static pressure (see also the chapter "Valves"). Open and remove the tank cap so that air enters the tank.
6. Open the venting plug on the pump block, tilt the power unit backwards by approx. 45° (see illustration) and wait until oil comes out from the bolt.

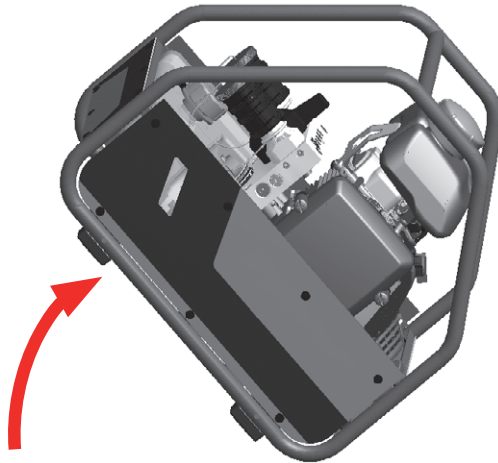
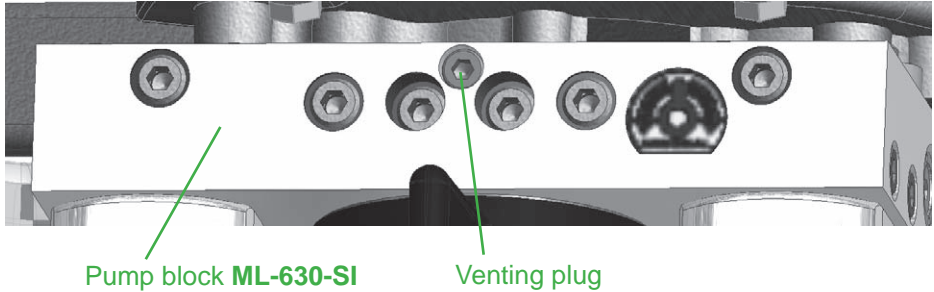

7. When oil comes out at the venting plug, the air has been removed from the pump. First close the venting plug and then return the power unit to the level.
8. Check the fluid levels. Top up if necessary.
9. Now connect the extension hoses and/or hose reels (unless already connected to the unit) and/or couple the rescue equipment.

7.2.3 Commissioning (after the first filling or prior to use)

1. Check the fluid level of the engine oil, the hydraulic fluid and the fuel tank. Top up if necessary. For precise reading off of the fluid levels and for filling, the hydraulic unit should be as level as possible.
2. Now connect the extension hoses and/or hose reels (unless already connected to the unit) and/or couple the rescue equipment.

8. Operation



ATTENTION!

The control levels on the hydraulic power unit should always be switched to the neutral position (de-pressurised) **prior to starting the engine** in order to prevent unwanted movements of connected hydraulic equipment and to start the power unit without hydraulic load.

8.1 Starting the engine

Before starting the combustion engine, check that the fuel tank is full and that the engine oil level is within the permitted tolerances. If necessary, top up the relevant fluid.

1. Open the gasoline tap
2. Set the ON/OFF switch to the ON position.
3. Move the lever from switching position A to switching position B (choke) when starting cold
4. Pull the cable-starter.
5. When the motor is running, switch the lever back to position A.



For the detailed procedure for starting the combustion engine, please see the separate operating instructions of the engine manufacturer!

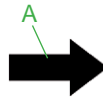

8.2 Turning the engine off

1. Set the ON / OFF switch to the OFF position.
2. When the engine has come to a standstill, close the fuel tap.



For more details on switching off the engine, please refer to the separate operating instructions of the engine manufacturer!



CAUTION!

Never touch hot engine parts: this could result in severe burns!

8.3 Refuelling

The engine must be switched off for refuelling!

Procedure:

1. Open the fuel tank cap.
2. Fill the tank with fuel until the fill level is just below the filler opening.



WARNING/CAUTION!

Be sure not to spill fuel. In particular, hot engine parts must not come into contact with fuel; danger of fire otherwise!



If fuel is spilled, it must be cleaned up immediately with a suitable absorbent cloth. In doing so, be careful not to burn yourself on one of the hot engine parts! The used cloth must then be cleaned or disposed of according to the relevant provisions and guidelines!

3. Close the fuel tank again with the fuel tank cap.

8.4 Controlling the valves



ATTENTION!

The control levels on the hydraulic power unit should always be switched to the neutral position (de-pressurised) **prior to starting the engine** in order to prevent unwanted movements of connected hydraulic equipment.

8.4.1 "Simultaneous operation" control valve (SIMO) ML-630-SI

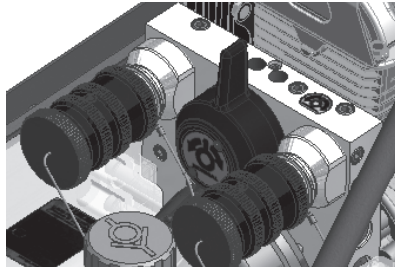

A switching lever that controls the valves (see the top illustration) is located on the pump block. Both mono-couplings have been designed in such a way that they are automatically in the de-pressurised state without connected device. The control unit on the device controls the switching when the device is connected. The switching lever makes it possible to switch to the "TURBO" function. With this function, one of the two connections is able to be supplied with double the feed volume by switching the lever.

The "TURBO" function is activated by turning the large lever towards the connection that is to be pressurised at the doubled pumping output.



NOTE:

All switching levers must always be completely switched on up to the end stop.

9. Dismantling the equipment / deactivation following operation

Once the work has been completed, all connected equipment is to be reset to its neutral position (storage position) before the unit is shut down. You can then switch off the engine of the power unit.



WARNING for power units with combustion engines!

Check that the engine switch is set to the "OFF" position and remains there to prevent the unwanted starting of the power unit!

Mono-couplings:

If the connected hose assemblies are to be dismantled during shut-down, decouple as described in chapter "Coupling the mono-couplings". Ensure that you put the dust protection caps back onto the mono-coupling halves.

Clean the hydraulic power unit of any stubborn dirt prior to storage.

If the equipment is to be stored for a longer period of time, the exterior is to be cleaned completely and the mechanically mobile parts are to be lubricated. If storing a unit with combustion engine, you should also remove the fuel from the fuel tank.

Avoid storing the hydraulic power units in a damp environment.

Observe the additional regulations in the separate operating instructions for the hoses.



CAUTION!

Depending on the size and weight of the hydraulic power unit it should be transported to the storage location by one or more persons.

10. Tests

The hydraulic power units are subject to very high levels of mechanical stress. A visual inspection must therefore be carried out after every use and at least one visual inspection must be carried out every six months.

This reveals wear and tear in good time; punctual replacement of these wearing parts prevents damage to the equipment. Also check regularly that all the securing screws are tightened (if applicable, comply with prescribed tightening torques)



ATTENTION!

Clean off any dirt before checking the equipment!



WARNING/CAUTION!

To perform inspections, maintenance and repairs, personal safety equipment appropriate for the work is an absolute requirement. (when necessary also use screens).



HURST offers a suitable test kit for the function test of the hydraulic units.

(For specific details, please consult the HURST range of accessories or contact your HURST dealer.)

10.1 Recommended test intervals

10.1.1 General visual inspection

A visual inspection must be carried out after every use, but at least once every six months.

10.1.2 Function check

<i>Operating time per day</i>	<i>Functional test</i>
up to 1 hour	1 x annually
up to 8 hours	1 x per quarter
up to 24 hours	1 x per month

In addition to these test intervals you need to carry out a function test if:

- *the unit makes suspicious noises,*
- *there is a justified suspicion of internal damage to the unit.*

If the noises and suspicions referred to above arise several times in a month, or if maximum pressure cannot be achieved during the function test, you need to contact HURST customer service immediately. The contact details are given in the Chapter "Fault analysis".

10.2 Visual and function check

Visual Inspection

- Tightness of all hydraulic connections,
- General tightness, no leakage (sweated oils do not have any influence on the function),
- is there any detectable damage to the engine, connecting blocks, on the frame or the side sections,
- Is there any sign of damage to the hydraulics or fuel tank,
- Side plates present and tightened,
- Presence and legibility of the identification plate, all actuation signs, instruction signs, markings and warnings,
- The presence and perfect condition of all covers (e.g. exhaust deflector),
- All fluid levels are within the specified tolerances,
- Are the rotary switches and switching levers in proper working order and undamaged,
- Couplings must be easy to couple,
- Dust protection caps must be available,
- All required accessory parts (e.g. sparking plug, sparking plug spanner and fuel can) are present.
- Check for leaks.

Functional test

- Unconventional or noticeable noises heard during operation
- Cable-pull starter fully functional,
- Engine switch fully functional,
- Test for maximum load.

**NOTE:**

use the HURST test kit, including testing instructions, for the function test.

11. Maintenance and repair

11.1 General information

HURST hydraulic units model ML-630 require only limited maintenance. For service work, special training is unnecessary; however, knowledge of the function of the power unit, the legal safety instructions and dealing with the required tools are basic prerequisites.



ATTENTION!

Never use unnecessary force during maintenance work that could damage the components of the power unit or compromise operational safety.

Due to safety reasons and the complex installation, service work on the hydraulic power unit must only be executed by the equipment manufacturer, personnel trained by the equipment manufacturer, or authorised HURST dealers.



WARNING/CAUTION!

Protective clothes must be worn when maintenance and repairs are being carried out, since the devices may also be pressurised when not in operation.

During work, ensure that all components are particularly clean, since dirt can damage the rescue equipment!



ATTENTION!

Since HURST hydraulic units are designed for top performance, only those components in the replacement parts lists for the relevant unit can be replaced. Any other components in the unit may only be replaced if:

- You have participated in an appropriate HURST service training course.
- You have the express permission of HURST customer service (upon request, we will check for the grant of permission. Examination in each individual case necessary!)

When cleaning units and equipment, note that no cleaning agent may be used that has a pH value outside the range 5 - 8!



ATTENTION!

Attention must be paid to ensuring that no operating fluids can escape from units with combustion engines during repair work!

11.2 Service work on the hydraulic unit

11.2.1 Care instructions

The exterior of the device must be cleaned from time to time (**not the electrical contacts**) and the metallic surfaces (**not the electrical contacts**) must be treated with a suitable agent to protect against corrosion.

(In case of doubt, contact your authorised HURST dealer or HURST directly!)

11.2.2 Function and load test

If there is any doubt regarding the safety or reliability of the equipment, a function and stress test must also be performed.

HURST offers appropriate testing equipment for this.

11.2.3 Replacing the hydraulic fluid

- After approx. 200 deployments, but after three years at the latest, replace the hydraulic fluid.
- The fluid should be replaced after it has warmed up.
- The engine must be switched off!
- The used hydraulic fluid must be disposed of properly.

Replacing the hydraulic fluid - procedure:

1. Place the power unit on a slightly elevated base so that the drain plug for the hydraulic fluid can be easily reached.
2. Place a suitable collection container under the "A" drain plug.
3. Open the "B" filler cap, remove the "A" drain plug and let the hydraulic fluid run into the provided collection container.
4. Screw the "A" drain plug in again (tightening torque max. 5 Nm).

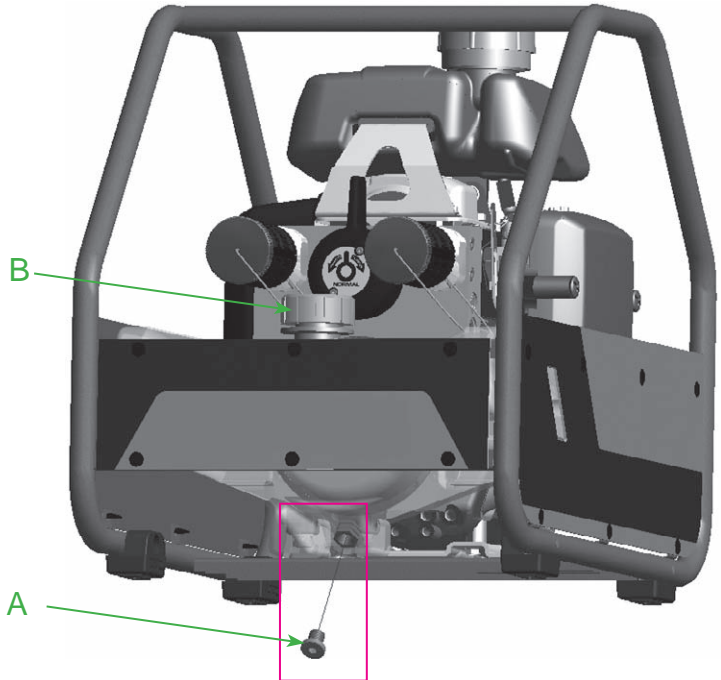

5. Pour the new hydraulic fluid through the filler neck into the hydraulic tank and close the neck again with filler cap "B".
6. The unit then has to be bled again as described in the Chapter "Commissioning".

11.2.4 Changing decals

All damaged and/or illegible decals (safety notices, type plate etc.) must be replaced.

Procedure:

1. Remove damaged and/or illegible decals.
2. Clean surfaces with industrial alcohol.
3. Affix new decals.

Take care to affix the decals in the correct positions. If this is no longer known, you should ask your authorised HURST dealer or contact HURST directly.

11.3 Additional service work



NOTE:

Non-observance of the maintenance plan can lead to malfunctions that are not covered by the warranty.

For dismantling the sparking plug, use a commercially-available sparking plug spanner with universal joint and spanner size of 16 mm (5/8 inch).

A straight/rigid sparking plug spanner would damage or break off the sparking plug!

(also observe the separate instructions from the engine manufacturer)

First month or after the first 20 hours (first time):

- Replace engine oil (see operating instructions of the engine manufacturer).

*You must conduct the following service measures every **50 operating hours**:*

- Clean the air filter element.
- After using in a dusty environment, inspect the air filter element and clean immediately, if necessary.

*You must conduct the following service measures every **100 operating hours**:*

- Replace engine oil.
- Check the sparking plug, clean if necessary / set the electrode gap of the sparking plug

*You must conduct the following service measures every **200 operating hours**:*

- Replace the sparking plug
- Replace air filter

(The following service work should be executed by an authorised dealer, HURST directly or the engine manufacturer.)

*You must conduct the following service measures every **300 operating hours**:*

- Replace the sparking plug and the filter element
- Clean and adjust the carburettor, valve clearance, valve seat and cylinder head.

*You must conduct the following service measures every **1000 operating hours** or **every 2 years**:*

- Check the starter
- Inspect the engine for damage
- Check the fuel line and replace, if necessary.

11.3.1 Replacing and cleaning the air filter



NOTE:

Keeping the air filter in good condition is extremely important. Penetrating dirt leads to damage and wear in the engine in case of incorrect installation, incorrect damage or unsuitable filter inserts. Always keep the air filter insert clean.

Procedure:

If present, remove the rear side panel of the hydraulic power unit, in that the fixing clip and the side panel are removed.

1. Unscrew both bolts from the air filter cover and remove the cover.
2. Remove the foam air filter insert from the cover.
3. Take the paper air filter insert from the air filter housing.
4. Check both air filter inserts and replace if damaged. The paper air filter insert must always be replaced at planned intervals.
5. Clean the air filter inserts if reusing them.

Paper air filter insert: Tap out the paper air filter insert a few times on a hard surface to remove dirt or blow compressed air [not more than 207 kPa (2.1 kg/cm)] from the air filter housing side through the filter insert. Never attempt to brush out dirt because it would be pressed in by the bristles. Replace the paper air filter insert if it is exceedingly dirty.

Foam air filter insert: Clean in warm soapy water, rinse and allow to dry thoroughly. Or clean in non-flammable solvent and let dry. Do not introduce any oil to the foam air filter insert.

6. Wipe away dirt from the inside of the air filter housing with a damp cloth. Ensure that dirt does not penetrate the air duct leading to the carburettor.
7. Then re-fit the filter.

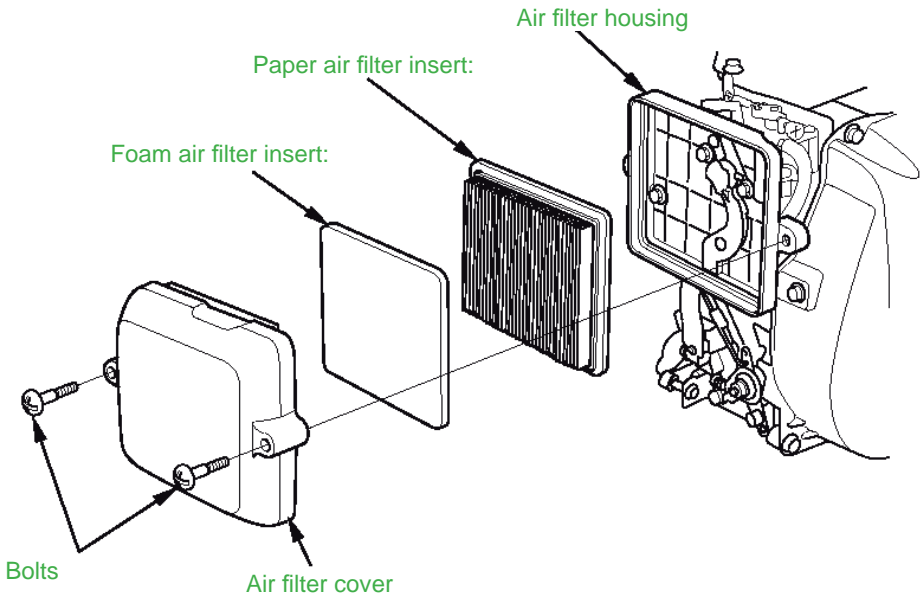

11.3.2 Replacing, cleaning and setting the sparking plug

Procedure:

In order to deliver good performance, the sparking plug must have a correct electrode gap and be free from deposits.

1. Detach the sparking plug connector and remove any dirt near the sparking plug.
2. Unscrew the sparking plug using a 16 mm (5/8 inch) sparking plug spanner.
3. Check the sparking plug. Replace the sparking plug if it is damaged, extremely dirty, the sealing washer is in poor condition or the electrodes are worn.
4. Measure the electrode gap on the sparking plug with a wire feeler gauge. Correct the electrode gap, if required, by carefully bending the side electrode. Target electrode gap: 0.6 - 0.7 mm (0.024 - 0.028 in)
5. Carefully screw in the sparking plug by hand in order to avoid stripping the thread.
6. Tighten the sparking plug after mounting with a 5/8-inch sparking plug spanner in order to compress the washer.
7. A new sparking plug should be tightened by an additional 1/2 turn after fitting in order to compress the washer.
8. A used sparking plug should be tightened by an additional 1/8 to 1/4 turn after fitting in order to compress the washer.
9. Place the sparking plug connector on the sparking plug.



NOTE:

A loose sparking plug can overheat and damage the engine.

A sparking plug that is too tight can damage the thread in the cylinder head.

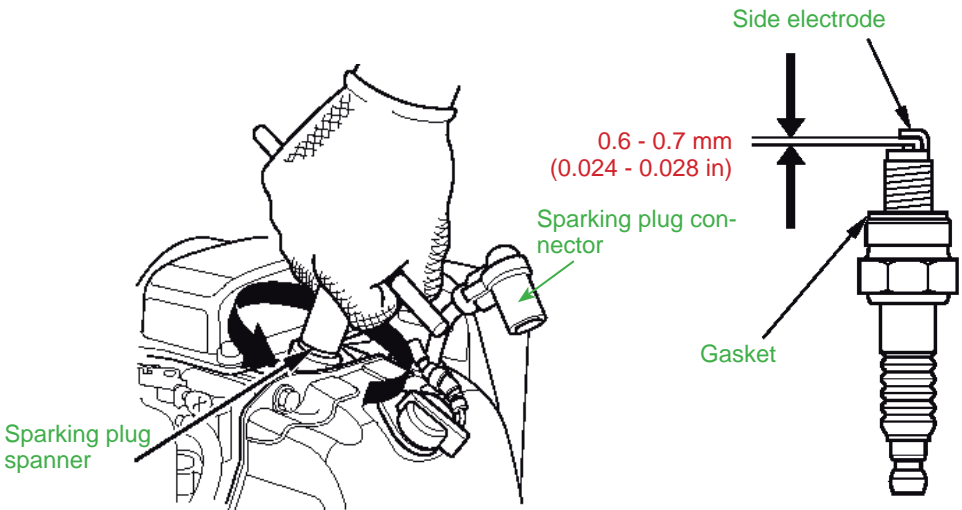

11.3.3 Replacing the engine oil and the engine oil filter

For the procedure for replacing the engine oil and engine oil filter, please refer to the separate operating instructions of the engine manufacturer!

11.3.4 Mono-couplings

The mono-couplings must be replaced if:

- there is external damage,
- the locking does not function,
- hydraulic fluid continues to leak in the coupled/uncoupled state.



WARNING/CAUTION!

Never repair couplings: they must be replaced by genuine HURST parts!



Procedure for coupling to valve block:

1. First empty the hydraulic tank as described in the chapter "Replacing the hydraulic fluid".
2. Remove screwed fittings on the coupling.
3. Remove couplings and underlying seals
4. Position the new coupling, together with the seals, onto the valve block.
5. Re-attach the couplings with the bolts and tighten to a torque of $M_A = 40 \text{ Nm}$.
6. The hydraulic fluid tank must be refilled and the power unit vented.

Procedure for coupling to hose pairs:

1. First empty the hydraulic tank as described in the chapter "Replacing the hydraulic fluid".
2. Pull the cover back from the couplings.

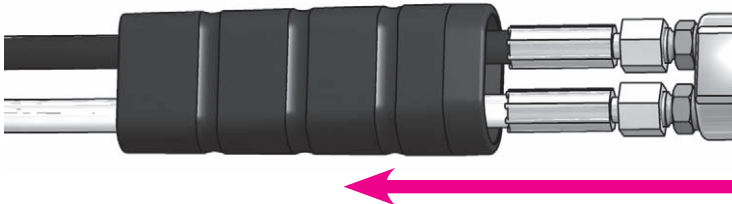

3. Loosen the union nuts on the hose lines and remove the coupling.

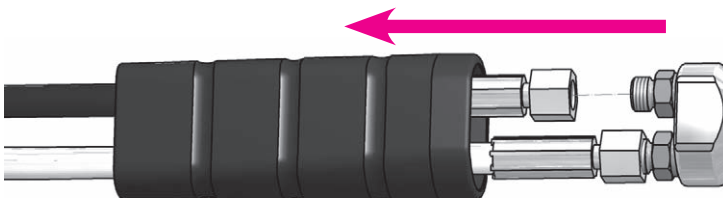

**ATTENTION!**

Ensure that connection "T1"/"T2" on the pump block is always connected to connection "T" on the mono-coupling.

4. Position the new coupling and tighten the union nuts on the hose assemblies to a torque of $M_A = 40 \text{ Nm}$ and push the cover of the couplings back.



5. The hydraulic fluid tank must be refilled and the power unit vented.

11.3.5 Quick-disconnect couplings

The quick-disconnect couplings must be replaced if:

- there is external damage,
- the locking does not function,
- hydraulic fluid continues to leak in the coupled/uncoupled state.

**WARNING/CAUTION!**

Never repair couplings: they must be replaced by genuine HURST parts!



During assembly tighten the union nuts on the hose line to a torque of $M_A = 35 \text{ Nm}$.

Procedure:

1. Loosen the union nuts on the hose line and remove the coupling.
2. Position the new coupling and tighten the union nut on the hose assemblies to a torque of $M_A = 35 \text{ Nm}$.

**ATTENTION!**

The return hose, which is screwed onto the port "T" of the rescue tool, must be equipped with a quick-disconnect-coupling (male) always. However, the supply hose line must be equipped with a quick-disconnect-coupling (female).

12. Fault analysis

Fault	Check	Cause	Solution
<p>Combustion engine will not start</p> <p>NOTE: In case of faults which directly affect the combustion engine, please also observe the separate instructions in the operating instructions of the engine manufacturer.</p>	Check fuel level in tank	Fuel tank empty	Top up fuel
	Check fuel line	Fault in the fuel line	Shut down immediately and have repaired by authorised dealer, motor / engine manufacturer or directly by HURST
	Inspect engine switch	Cable-pull starter	Activate cable-pull starter
		Motor switch not set to Choke	Set motor switch to Choke
	Hydraulic unit or engine not suitable for the working environment	Ambient temperature too low	For the solution, consult the separate operating instructions of the engine manufacturer.
			Use a different hydraulic fluid or operating fluid that is suitable for the relevant ambient temperature (see Chapter I "Technical Data")
			Not enough oxygen in the air because of the altitude of application location of the hydraulic motor
			Use a different more suitable hydraulic unit.
			Have the engine set to the altitude of application of the hydraulic power unit by an authorised dealer, engine manufacturer or HURST directly (only if the unit is to be used frequently at this altitude).
	Check air filter	Air filter contaminated	Clean or replace the air filter.
Are all valves set to pressure-free (rest setting)?	Combustion motor defective or overloaded due to different defect in the unit	Have repaired by authorised dealer, motor / engine manufacturer or directly by HURST	

Fault	Check	Cause	Solution
The motor is running, but the connected rescue equipment is not moving / moving very slowly upon activation of the valve.	Check hose	Hose assembly not connected properly or is damaged	Check connection of hose and reconnect if necessary.
	Check the switch position of the valve lever on the pump block of the hydraulic unit	Valve not switched to supply line pressurisation.	Switch valve to pressure load of the supply line.
		Defective pump unit	Have repaired by authorised dealer or directly by HURST
	Connect a different unit and check whether it works when actuated	The previously connected unit is defective.	Rectification see operating instructions of the connected unit
		Mono-coupling (female) defective	Replace mono-coupling (female)
The connected rescue equipment does not move on activation of the valve, or moves only very slowly or unevenly.	Connect a different unit and check whether it works when actuated	The previously connected unit is defective.	Rectification see operating instructions of the connected unit
	Check the switch position of the valve lever on the pump block of the hydraulic unit	Pressure relief on the unit is still active (circulation at static pressure)	Check the switching positions of the valve lever(s) and, if necessary, reset (as far as the final position)
		Defective pump unit	Have repaired by authorised dealer or directly by HURST
		Air in hydraulic system	Vent the hydraulic system
		Plug-in coupling (female) defective	Replace plug-in coupling (female)
		Mono-coupling (female) defective	Replace mono-coupling (female)

Fault	Check	Cause	Solution
Connected rescue device does not reach its final position	Check hydraulic fluid volume in hydraulic tank	Insufficient fluid in the hydraulic tank	Top up hydraulic fluid to the maximum filling level Caution! Before topping up the rescue equipment, return to the base position!
		Usable hydraulic fluid volume of the unit is insufficient	Use a different rescue device with a demand quantity below the maximum usable quantity of the unit
Connected rescue device does not reach its specific performance data		Maximum permitted operating pressure of the pump is not reached	Have the pressure limiting valve reset or repaired by authorised dealer or directly by HURST
		Pump block defective	Have repaired by authorised dealer or directly by HURST
		Connected unit defective	Rectification see operating instructions of the connected unit
During function test: A pressure gauge installed between the rescue equipment and the hydraulic power unit does not indicate the maximum operating pressure of the equipment.	Check the details of the rescue device	The operating pressure of the connected rescue device is locked internally	No repair or fault rectification required
		Connected rescue device is defective	Consult the separate operating manual for the connected rescue device
		Hydraulic unit defective	Have repaired by authorised dealer or directly by HURST

Fault	Check	Cause	Solution
Fluid coming out from hydraulic fluid tank	Connected unit not in base position yet and fluid coming out of filler cap?	Return of the hydraulic fluid from the rescue device exceeds the tank's maximum quantity when filled.	Reduce fluid level in the hydraulic tank to "Minimum" mark, move the unit to the base position and then fill back up with hydraulic fluid to the "Maximum" level
	Fluid leaks from a different location?	Leak from tank, lines or seals	Replace defective components or repair by authorised dealer or HURST directly
Leaking fluid between engine and flange bearing		Radial shaft seal on the drive shaft is defective	Have repaired by authorised dealer or directly by HURST
Hydraulic fluid milky and cloudy		Water / condensation in the system	Replace the hydraulic fluid immediately
Hoses cannot be coupled		Pressure too high (e.g. caused by ambient temperature too high)	Switch valve block to circulation at static pressure
		Coupling defective	Coupling must be replaced immediately

Fault	Check	Cause	Solution
It is frequently not possible to couple hose assemblies		Hydraulic fluid not adapted to the application situation	Hydraulic fluid must be replaced (see chapter "Recommended hydraulic fluids")
		Coupling defective	Coupling must be replaced immediately
Leak in the couplings		Coupling defective	Coupling must be replaced immediately
Leakage at the drive shaft of the hydraulic pump		Shaft seal defective.	Repair by an authorised dealer, by personnel specially trained by HURST, or by HURST itself

NOTE:

In case of faults which affect the combustion engine, please also observe the instructions in the separate operating instructions of the engine manufacturer.

Contact an authorised HURST dealer or the HURST Customer Service Department directly if the malfunctions cannot be rectified.

The address for the HURST Customer Service department is:

<p><i>HURST</i> JAWS OF LIFE, INC <i>A Unit of IDEX Corporation</i></p> <p>711 N. Post Road Shelby, NC 28150 USA Phone: (704) 487-6961 Fax: (704) 487-7271 e-mail: contacthurst@idexcorp.com</p>

13. Technical data

Because all values are subject to tolerances, there may be small differences between the data for your device and the data in the following tables!

The values may also differ because of reading inaccuracies and/or tolerances in the measuring equipment used.



NOTE:

The following tables contain only the technical data required for standard acceptance.

Additional data concerning your unit can be obtained from HURST on request.
The limitation of the max. fill quantity of the hydraulic tank results from the "operability at an incline" prescribed in the standards.

13.1 Power Unit

13.1.1 Basic dimensions of the power unit (mm [inch])

Power unit ML-630-SI:

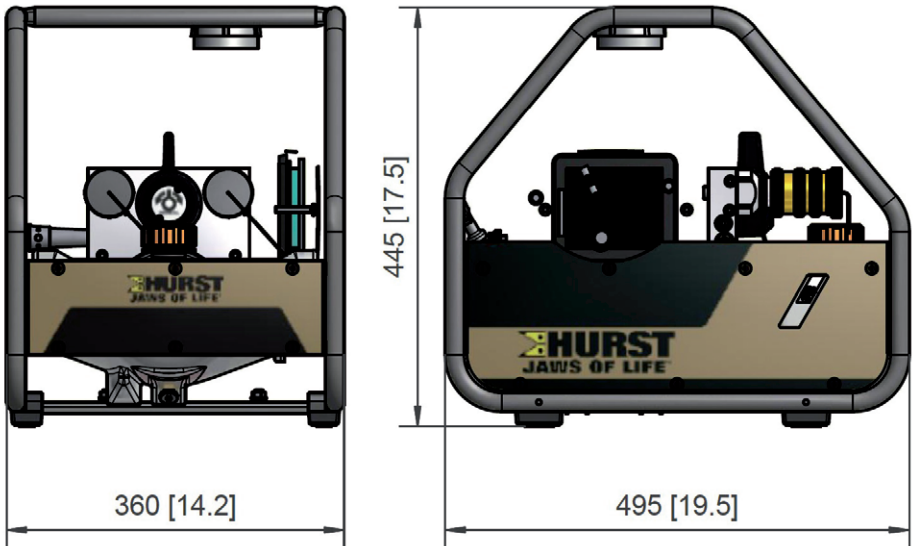

13.1.2 Technical data ML-630-SI

Device type		ML-630-SI
Article number		375070000
Motor type		4-stroke gasoline engine
Engine power rating	[kW]	2.2
	[HP]	3.0
Engine speed	[min ⁻¹]	3000 / 3800
	[rpm.]	
Feed rate simultaneous (HD) ¹⁾	[l/min]	2 x 1.0 / 2 x 1.2
	[gal.-US/min]	2 x 0.27 / 2 x 0.32
Feed rate turbo (HD) ¹⁾	[l/min]	1 x 1.9 / 1 x 2.4
	[gal.-US/min]	1 x 0.51 / 1 x 0.63
Feed rate simultaneous (ND) ²⁾	[l/min]	2 x 2.6 / 2 x 3.2
	[gal.-US/min]	2 x 0.69 / 2 x 0.85
Feed rate turbo (ND) ²⁾	[l/min]	1 x 5.1 / 1 x 6.3
	[gal.-US/min]	1 x 1.35 / 1 x 1.66
Max. operating pressure (HD) ¹⁾	[MPa] ³⁾	70
	[psi.]	5000
Max. operating pressure (ND) ²⁾	[MPa] ³⁾	14
	[psi.]	2000
Max. fill volume hydraulic fluid	[l]	2.2
	[gal.-US]	0.58
Max. fill volume Gasoline	[l]	0.77
	[gal.-US]	0.17
Weight (with gasoline and hydraulic fluid)	[kg]	24.6
	[lbs.]	54.2
Valve variants		Simultaneous operation
Max. unit connection facilities		2

¹⁾ HD = High pressure

²⁾ ND = Low pressure

³⁾ 1MPa = 10 bar

13.2 Noise emissions

Device type		ML-630-SI	
Speed		3000 [1/min] / [rpm]	3800 [1/min] / [rpm]
No-load operation (acc. to EN)	[dB(A)]	80	84
Full-load operation (acc. to EN)	[dB(A)]	84	88
No-load operation (acc. to NFPA)	[dB(A)]	73	77
Full-load operation (acc. to NFPA)	[dB(A)]	77	80

Explanation of dual number noise emission values according to DIN EN 13204:2012-09
Serial number of the machine, operating conditions and other characteristic properties:
Model ...ML-630-SI, type ...375070000, maximum working pressure ...500 bar, engine speed3800 [1/min] / [rpm]
INDICATED DUAL NUMBER NOISE EMISSION VALUES according to EN ISO 4871
Measured A-rated emission sound pressure level
LpA, in dB, referred to 20 µPa88
Measurement uncertainty, KpA, in dB4
Measured A-rated emission sound power level (if required)
LWA, in dB, referred to 1 pW101
Measurement uncertainty, KpA, in dB4
Values determined according to EN 13204, Appendix B, using basic standards EN ISO 3744 and EN ISO 11201.
NOTE! The sum of the measured noise emission values and the associated measurement uncertainty that can occur during the measurement represent the upper limit of the measured values.

13.3 Sparking plug

Sparking plug type: CR5HSB (NGK)
U16FSR-UB (DENSO)

13.4 Sparking plug spanner

**Universal joint sparking plug spanner with spanner size 16 mm
(5/8 inch)**

13.5 Fuel

Fuel: Lead-free gasoline
ROZ 91 to ROZ 98

13.6 Engine oil

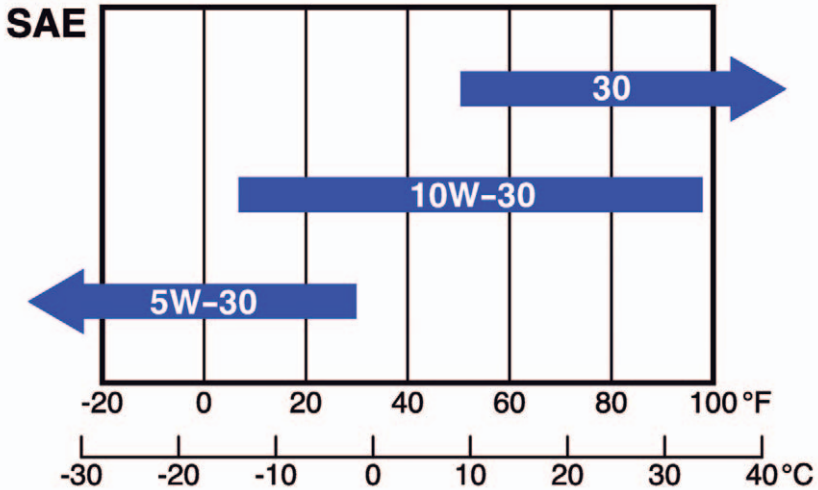

13.7 Hydraulic fluid recommendation

Mineral oil DIN ISO 6743-4 for HURST hydraulic equipment and others

	Oil temperature range	Oil designation	Viscosity rating	Remarks
A	-20 +55°C	HM 10	VG 10	

	Oil temperature range	Oil designation	Viscosity rating	Remarks
A	<i>-4.0 +131°F</i>	HM 10	VG 10	

recommended range of viscosity: 10...200 mm²/s (*10...200 cSt*)

Supplied with HM 10 DIN ISO 6743-4.



ATTENTION!

Before you use hydraulic fluids from a different manufacturer, you must contact HURST or an authorised dealer.

13.8 Operating and storage temperature range

Operating temperature	[°C] / [°F]	-20 ... +55	<i>-4 ... +131</i>
Storage temperature (device not in operation)	[°C] / [°F]	-30 ... +60	<i>-22 ... +140</i>

14. EC Declaration of Conformity



HALE PRODUCTS, INC. dba
HURST JAWS OF LIFE
A Unit of IDEX Corporation
7111 N. Post Road
Shelby, NC 28150
USA



Dinglee, LUKAS, Hurst, Vetter

IDEX Europe GmbH
Weinstraße 39
91 058 Erlangen
Germany

EC Declaration of Conformity

In accordance with the EC Machinery Directive 2006/42/EC, Appendix II A

We hereby declare that the following hydraulic power units

Item no.	Type
275070000	P 630 SG
275075000	P 630 SG lite

- in the versions supplied by us conform to the EC Machinery Directive 2006/42/EC (replaced directive 98/37/EC) and the national statutory provisions that implement them.

The following standards have particularly been taken into consideration:

- DIN EN ISO 12100:2010, publication date: 2011-03 – Safety of machinery - General principles for design - Risk assessment and risk reduction
- DIN EN 13204, publication date: 2012-09 – Double acting hydraulic rescue tools for fire and rescue service use – Safety and performance requirements.

This declaration loses its validity in the case of alterations or usage of the machinery/equipment not approved by HURST.

Carsten Sauerbier
Director of Technical Innovation and Development
IDEX Europe GmbH

Thomas Littwin
Engineering Designer

Erlangen, April 23, 2013

15. Notes



WARNING/CAUTION!

Before connecting the equipment, make sure that **all the components used are suitable for the maximum operating pressure of the hydraulic unit!** In cases of doubt, you **must consult HURST** directly before connecting the equipment!



Please dispose of all packaging materials and removed items properly.

HURST JAWS OF LIFE, INC

A Unit of IDEX Corporation

711 N. Post Road
Shelby, NC 28150 USA
Phone: (704) 487-6961
Fax: (704) 487-7271
e-mail: contacthurst@idexcorp.com

MADE IN USA