

EDrainic[®] 3

CONNECT

Operating Instructions

English | Español | Français | Português

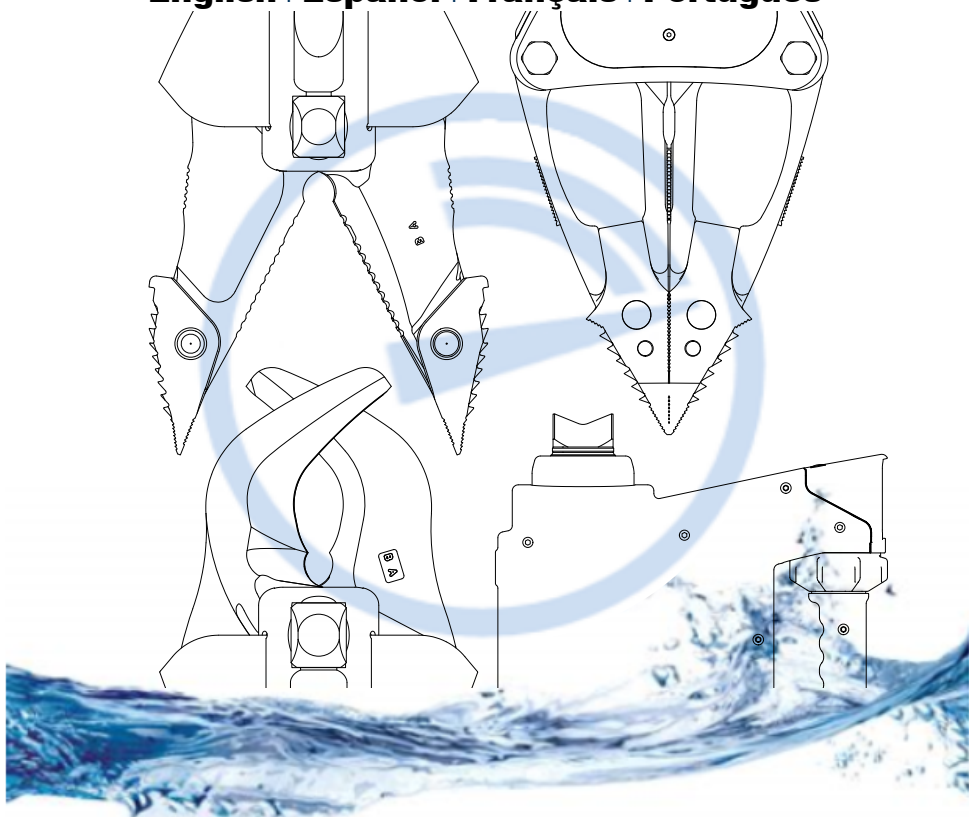

 **HURST**
JAWS OF LIFE[®]

en

es

fr

pt

I.

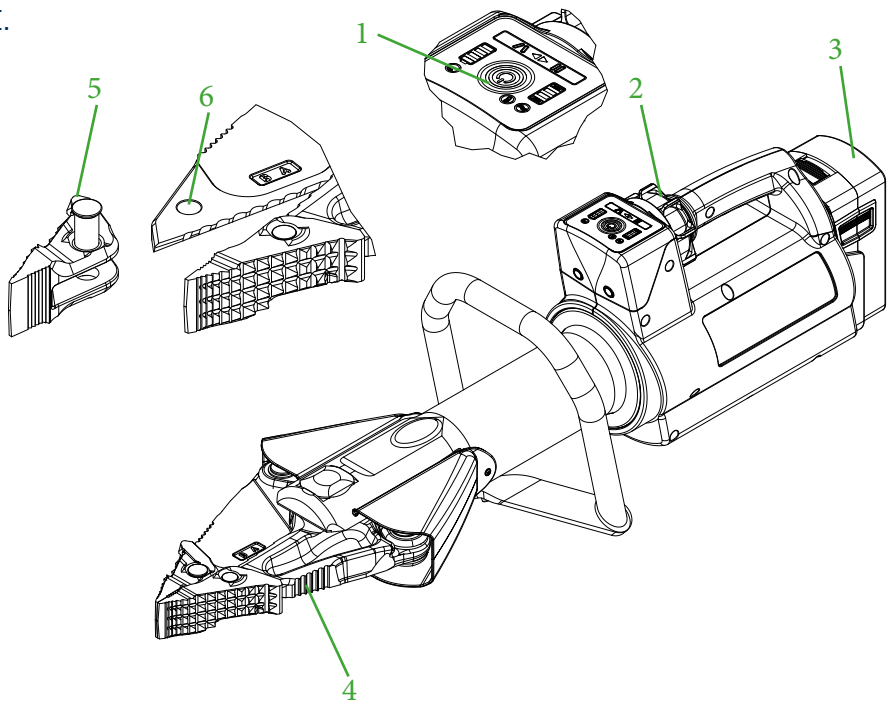

II.

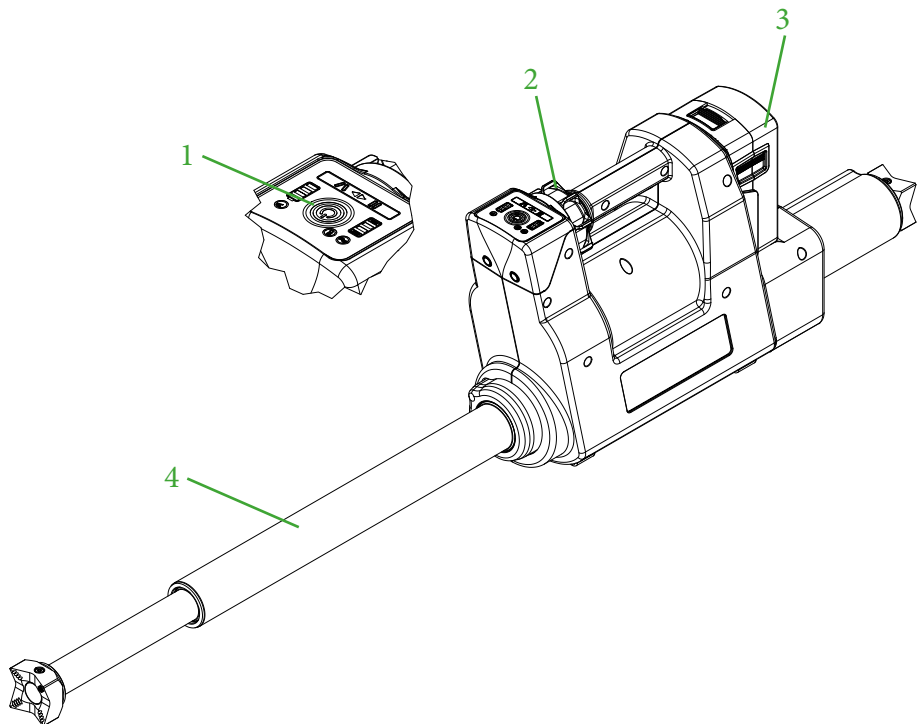

English4

en

Español.....22

es

Français.....42

fr

Português62

pt

CONTENTS

- 1. Proper use..... 5
- 2. Product safety and pictograms..... 5
- 3. Structure of the devices 8
- 4. Operating the devices 8
- 5. Display and control panel..... 10
- 6. Setting up data exchange with Captium™ 11
- 7. Maintenance and care..... 14
- 8. Troubleshooting 15
- 9. Explanation of pictograms for performance tables..... 17
- 10. Accessories..... 20
- 11. Instructions regarding disposal 21
- 12. Compliance Information 21

en

es

fr

pt

1. PROPER USE

The product described is an electro-hydraulic rescue device. The equipment is designed for rescuing persons or material assets following a traffic accident or natural disaster and during other rescue missions.

It must always be used in combination with HURST original accessories.

The manufacturer is not liable for damage resulting from improper use. The user bears sole responsibility for such use.

HURST E3 devices are suitable for underwater use up to a depth of 3 m and a duration of one hour. For use in salt water, a special salt water rechargeable battery is required; it is available from HURST as an accessory.

2. PRODUCT SAFETY AND PICTOGRAMS



The safety of the operator is the most important consideration in product design. Furthermore, the instruction manual is intended to help you use HURST products safely.

The generally applicable legal and other binding regulations pertaining to the prevention of accidents and protection of the environment apply and are to be complied with in addition to the operating instructions.

The device may only be operated by persons with appropriate training in the safety aspects of such equipment, otherwise, there is a risk of injury.

We would like to point out to all users that they should carefully read the instruction manual before using the device. All instructions contained must be followed without restriction.

We further recommend that you have a qualified trainer show you how to use the product.









	Read the instruction manual for the lithium-ion battery and battery chargers. This can be found at: https://akkupower.info/ewxt-saftysheet.pdf
	If the battery displays an error code, note and follow the information in the separate instructions for the battery.
	The operating instructions for accessories must also be taken into account.
	Please ensure that the accessories you use are designed to withstand the maximum operating pressure of the rescue device.
	The battery housing must not be damaged or subjected to mechanical stress as this can damage the cells inside. Damaged batteries may no longer be used.
	The battery must not be allowed to become fully discharged.
	The battery may not be short-circuited.
	Always allow wet batteries to dry before inserting into the charger.

en

es

fr

pt

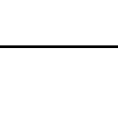
	Never work in a fatigued or intoxicated state!
	Always use the equipment as described in the section "Proper use".
	Please ensure that no body parts or clothing are caught between the moving parts.
	Always hold the equipment by the handles or housing. Do not touch the piston rods of the rescue rams!
	Working under suspended loads is not permitted if such loads are only supported by hydraulic or electro-hydraulic devices. If this work is unavoidable, sufficient mechanical supports are also required.
	Wear a helmet!
	Wear a face guard!
	Wear protective clothing! Provides protection in hot and cold working environments and prevents injuries caused by sharp edges.
	Wear protective gloves!
	Wear safety shoes!
	Always wear ear protection when working in noisy environments. The noise of the equipment itself does not require ear protection.
	Inspect the device before and after use for visible defects or damage. The star grip valve must return to the central position by itself without fail.
	Report any changes immediately (including changes in operating behavior). If necessary, the device is to be shut down immediately and secured!



Do not carry out any changes (additions or conversions) to the device without obtaining the prior approval of HURST.

All safety instructions on the device must always be complete and in a legible condition.

Any mode of operation which compromises the safety and stability of the device is forbidden!

Safety devices must never be disabled!

Before switching on/starting up the device and during operation, make sure that nobody will be endangered by this.

Repairs may only be performed by a trained service technician.

Only genuine HURST accessories and spare parts may be used.

Please note that when working with the equipment, material could fall down or suddenly break free as a result of shearing, tearing or breaking.

Observe all intervals for recurring tests and inspections as described in the section "Maintenance and care".

The eDRAULIC devices and batteries are suitable for underwater use to a depth of 3m and a duration of 60 minutes. The special battery for salt water operation must be used in salt and sea water.

Swallowing or inhaling the hydraulic fluids can be detrimental to health. Avoid direct skin contact. Please note that handling hydraulic fluid can negatively affect biological systems.

Moving safety bolts, e.g. for removeable tips, must always be fully inserted and locked.

When using chain sets, make sure that the chains are attached in a straight line and that there are no knots in the chain.



When working near live components, high voltage flashovers and the passage of current to the device must be avoided.

Prevent the electrostatic charging of the device.







HURST eDRAULIC devices are not explosion-protected! Use in explosion-protected areas is forbidden.

en

es

fr

pt

	Please ensure that you do not become entangled in cables and trip when working with or transporting the device.
	Ensure adequate lighting at the location of use and on the way there.
	<p>Always allow wet batteries to dry before inserting into the charger.</p> <p>Always keep this instruction manual in an easily accessible location close to the device at the place of operation.</p> <p>eDRAULIC devices have protection class IP58. They can be used for up to 60 minutes and to a depth of 3m under water.</p> <p>When working with or storing the device, ensure that the function and the safety of the equipment are not impaired by the effects of high temperatures or that the device is not damaged in any way. Observe the temperature limits for operation and storage of the devices. Please note that the device can heat up over a long period of use.</p> <p>Before transporting the device, always ensure that the device, battery and accessories are firmly secured.</p>
	Dispose of all removed parts, hydraulic fluids and packaging materials properly.

3. STRUCTURE OF THE DEVICES

Page 2

- 1 Device indicator (Figure M)
- 2 Star grip valve
- 3 Battery
- 4 Tool
- 5 Removeable tips
- 6 Draw / Bolt hole

4. OPERATING THE DEVICES

4.1. REPLACING THE BATTERY

Push the battery from above into the battery slot until it locks in place (figure A).

4.2. REMOVING THE BATTERY

Release the lock and remove the battery (figure B).

4.3. QUERYING THE BATTERY STATUS

Press the query button on the battery (figure C). Note also the separate instructions for the battery.

4.4. FLASHLIGHT FUNCTION OF THE BATTERY

To switch on the flashlight, press the query button on the battery twice in quick succession (Figure C.). To switch it off, press the query button again. The flashlight function automatically switches off again after a while.

4.5. SWITCHING ON AND OFF

To switch on, press the main switch (Figure M; No. 1). The device is ready to operate when the main switch and workspace lighting are illuminated blue. To switch off, the main switch must be pressed for three seconds.

4.6. ACTUATING THE STAR GRIP VALVE

The working action is triggered by turning the star grip valve. (Figure D). Every rescue device has a deadman function. When the star grip is released, it returns to the center/neutral position automatically. This ensures the load is retained.

4.6.1. CUTTING

Turn the star grip valve in the closing direction. (Figure E).

Position the cutter as perpendicular as possible to the object to be cut (Figure F). Cut close to the pivot point of the blade (Figure G).

4.6.2. SPREADING

Turn the star grip valve in the opening direction (Figure H).

Open a small gap at the start, then insert the spreader tips as far into the gap as possible. Do not spread with the aluminum arms! (Figure J).

4.6.3. PULLING

Secure the traction device in the attachment / bolt hole (page 2; figure I; number 6) or on the spreader tips. Actuate the star grip valve in the closing direction. (Figure E). Note the separate instruction manual for the traction device.

4.6.4. SQUEEZING

Only squeeze in the squeezing area and with the squeezing plates of the spreader arms (Figure K). Actuate the star grip valve in the closing direction. (Figure E).

4.6.5. PEELING

Special peeling tips are needed for peeling (Figure L). Actuate the star grip valve in the opening direction. (Figure H).

4.6.6. PUSHING

Place the rescue rams between the object to be pushed and actuate the star grip valve in the extending direction. (Figure H).

4.6.7. LIFTING

Actuate the star grip in the opening direction (figure H). When lifting vehicles or other moving loads, make sure that the load is prevented from sliding away and that the spreader tips are placed far enough under the load to prevent slipping. Constantly monitor and support the load when lifting.

4.7. REPLACING THE TIPS (SC AND SP ONLY)

The removable tips are connected to the device arm with bolts. To remove the tips, the bolts must be fully pushed in and then fully locked again (page 2; figure I; numbers 5+6)

4.8. ATTACH THE EXTENSIONS (R 320 AND CR 522)

The rescue rams can be adapted to the respective operating situation by attaching various extensions. To do this, the rear claw can be removed without tools and the suitable extension attached (Figure Q). Make sure that the replaceable parts are always fully inserted.

4.9. AUTOMATIC SWITCH-OFF

If the rescue device is not activated for a period of 60 minutes, it switches off automatically.

4.10. DISMANTLING/SHUTTING DOWN AFTER OPERATION

Once work has been completed, the device arms should be closed until the tips are only a few millimeters apart and the ram piston should be fully retracted and then extended a few millimeters. This relieves hydraulic and mechanical strain on the device. For transport and storage, all devices should be secured and not loosely stored.

5. DISPLAY AND CONTROL PANEL

5.1. MAIN SWITCH (FIGURE M; NO. 1)

For cutting and combination devices, the main switch includes the indicator for the cutting angle monitoring. (Figure F.) If the device twists to the right or left by an angle critical for the blade stability during the cutting process, the blue ring changes color to red. Attention! Check whether you can complete the cutting process without danger or whether you must reposition on the object to be cut.

5.2. BATTERY INDICATOR (FIGURE M; NO. 2)

The battery indicator indicates the current battery capacity. In WiFi mode, the battery indicator indicates the signal power.

5.3. LOAD INDICATOR (FIGURE M; NO. 3)

The load indicator scale indicates the tool's pressure range while working, and provides information about the remaining capacity. The load indicator also indicates whether the device is sending or receiving data via WiFi.

5.4. CONTROL LIGHT FOR THE TURBO FUNCTION (FIGURE M; NO. 4)

The star grip can be moved by 20° in any direction; with a move starting at 15°, the turbo function is activated, the device moves faster. The turbo function is only available in the low-pressure range.

en

es

fr

pt

10

5.5. CONTROL LIGHT FOR SALTWATER BATTERY (FIGURE M; NO. 5)

The control light indicates when a saltwater battery is plugged into the device.

5.6. WARNING LIGHT FOR ELECTRONICS TEMPERATURE (FIGURE M; NO. 6)

The device independently monitors the temperature of the electronics and emits a warning if the temperature reaches a critical range. In case of increased electronics temperature, no more turbo mode is available.

Furthermore, the device monitors the battery temperature, and with a cell temperature of less than -10°C , it reduces the speed in order to warm up the battery. As soon as the battery is warm enough, all functions are available again at normal speed.

5.7. ILLUMINATED DIRECTION INDICATORS (FIGURE M; NO. 7)

Depending on the direction in which the star grip is moved, the device indicates the motion direction in the display field.

5.8. CONTROL LIGHT FOR WLAN CONNECTION (FIGURE M; NO. 8)

If there is a WLAN connection, the control light lights up.

6. SETTING UP DATA EXCHANGE WITH CAPTIUM™

6.1. SETTING DIFFERENT OPERATING MODES

Mode	Operating step	Display on the control panel
Firmware update	Hold the star grip in the closed position + ON/OFF for 7 seconds	Close symbol flashes + red light on main switch lights up
Self-test	Hold the star grip in the open position + ON/OFF for 7 seconds	Open symbol flashes + close symbol lights up
Protocol upload	Hold the star grip in the closed position + ON/OFF for 15 seconds	Close symbol flashes + red light on main switch lights up + WiFi symbol lights up
Router mode	Hold the star grip in the open position + ON/OFF for 15 seconds	Open symbol flashes + close symbol and WiFi light up

6.2. LOGGING INTO THE CAPTIUM HUB

Visit captiumconnect.com to log to the Captium Data Hub or sign in for an account, if you are a new user. Additional details for how to register your device, how to use the Captium Data Hub and more are located in the Support Center. The rescue device can also be operated without being connected to the Captium Data Hub.

6.3. ESTABLISHING A NETWORK CONNECTION

So that the rescue device can communicate with Captium, the network connections must be entered via which the communication should take place. If the access data for the network changes, the data must be re-entered in the rescue device.

Carry out the following steps consecutively.

6.3.1. SWITCHING ON ROUTER MODE ON THE DEVICE

To do this, move the star grip all the way to the right (figure H) and simultaneously press the main switch (figure M; no. 1) for 15 seconds. The rescue device now establishes a WLAN network.

6.3.2. SEARCHING FOR A RESCUE DEVICE WITH WLAN CAPABILITY

The network established by the rescue device can be found by a WLAN-capable device (mobile phone, tablet or laptop). Search in the available networks for the “Jaws of Life” network and enter the password “12345678”.

6.3.3. AFTER SUCCESSFUL CONNECTION

If there is a WLAN connection, scan the QR code (figure O) on the rescue device or enter the IP address **http://192.168.66.1/** into the Internet browser of your terminal device. Now the input screen for the network connection opens (figure P).

6.3.4. INPUTTING THE NETWORK INTO THE PAIRING APP

Now choose your network with which the rescue device is to communicate. To do so, the network name (figure P; no. 1) and password (figure P; no. 2) is required. The password (figure P; no. 3) must be entered twice. Between one and ten networks can be stored, via which the rescue device should exchange data with Captium. After you have entered the first network, confirm with the Next button (figure P; no. 4). After that, another network can be entered. After all networks have been entered, end the process by pressing the Finish button (figure P; no. 5). A confirmation screen appears, the WLAN symbol (figure M; no. 8) flashes and the workspace lighting is switched back on. Make sure that the following ports have been enabled in the network to be connected.

Port	Protocol	Purpose
123	UDP & TCP	Used to synchronize the time on the rescue device over the Internet via NTP.
8883	UDP & TCP	IoT Hub MQTT connection.
443	UDP & TCP	Device Provisioning Service HTTPS connection.

6.4. REGISTERING THE DEVICE IN THE CAPTIUM DATA HUB

Visit captiumconnect.com and locate the Support Center. There you will find instructions for how to sign up for an account, register your device, how to use the Captium Data Hub and much more.

6.5. AUTOMATIC SENDING OF PROCESS DATA

While you are working with the rescue device, the process data is collected in the internal memory. If there is data in this memory, a battery is plugged in, and the device is switched off, the rescue device will then search every 20 minutes for the networks it recognizes. If no connection with a network is possible, it will search again after 20 minutes. After three attempts, the rescue device will wait 45 minutes before carrying out a final search, after which it will interrupt the search and leave the data in the internal memory. If the rescue device can establish a connection, it sends the data to Captium and deletes the entry in the internal memory as soon as Captium has received the data. If the internal memory does not contain any data, the rescue device doesn't search for a network.

6.6. MONITORING THE BATTERY'S REMAINING CAPACITY

The devices monitor the battery capacity of the inserted battery. The device switches itself on every seven days to monitor the capacity. If the remaining capacity falls below 35%, the rescue device sends Captium an alarm if WLAN is available.

6.7. MANUAL SENDING OF PROCESS DATA

To send the process data manually, the upload command must be triggered as described in the operating modes. To do this, you must turn the star grip all the way to the left (figure E), and press and hold the main switch (figure M; no. 1) for 15 seconds.

6.8. PERFORMING A SOFTWARE UPDATE





After you have registered your device, Captium checks the software version installed on your rescue device, battery or charger, and indicates if there is a newer version. These updates should be carried out promptly. The device needs to be switched to "Firmware update" mode. To do so, turn the star grip all the way to the left (figure E) and press and hold the main switch (figure M; no. 1) for 7 seconds.

6.9. PERFORMING THE SELF-TEST

The rescue device can test itself in test mode and transmit the results to Captium for display. To do so, you must turn the star grip all the way to the right (figure H) and press and hold the main switch (figure M; no. 1) for 7 seconds. The device is now in test mode. After that, you will be guided through the process by the illuminated direction indicators. The device must first be closed completely and then opened all the way again without load and closed all the way again. When the procedure has ended, the power supply interrupted or the device is not activated for 20 seconds, it automatically switches back to normal operation. The results of the self-test can be called up in Captium.

6.10. WIFI CONNECTION QUALITY INDICATOR

A minimum WiFi signal strength is required for reliable data transmission. If WiFi is activated on the device, the signal strength is indicated by the battery status LEDs. The signal strength indicated by the LEDs is shown in the illustration below. From the user's point of view, this means that two or more LEDs indicate that the signal strength is sufficient for a reliable data transmission.

	RSSI > -57 dBm
	-57 dBm >= RSSI > -69 dBm
	-69 dBm >= RSSI > -80 dBm
	RSSI < -80 dBm

6.11. WLAN TECHNICAL DATA

Transmission standard: IEEE 802.11 b/g/n
Frequency range: 2412 - 2484 MHz
Maximum transmission power: 20 dBm

7. MAINTENANCE AND CARE

7.1. GENERAL MAINTENANCE

A visual check is to be carried out after each use. After every use, the lubrication of the moving parts and bolts must be checked and topped off with a suitable grease, if necessary. The torque of the central bolt on cutting and combination tools must also be checked. To do so, check the specifications in the spare parts lists.

Any dirt must be removed with a damp cloth. The rescue device should not come into contact with acids or alkalis. If this is unavoidable, clean the device immediately afterwards.

An annual inspection of the device is due each year and must be documented. The annual inspection must be performed by a person with the necessary expertise. A function and load test must be conducted every three years or in case of any safety concerns. Only testing equipment approved by HURST may be used. Please also observe the relevant domestic and international regulations on the maintenance intervals of rescue devices.

7.2. MAINTENANCE AFTER UNDERWATER USE

- Remove the battery after use. Rinse the device and battery several times in fresh, clean water. Immerse the device completely in order to fill the housing with clean water. Lift the device out and let it drain completely. Depending on the type of water (mud, sludge, algae, salt water, etc.) in which the device was used, repeat these steps another 2-5 times.
- Wipe the device and the battery with a clean, dust-free and damp cloth in order to remove any dirt and deposits.
- Perform function test.
- Leave the device to dry at room temperature in a well-ventilated location. 36 to 48 hours is recommended. During this drying time, the device is completely operational. For the rechargeable battery, observe the relevant instructions.
- Lubricate all exposed steel parts (shear blade, pressure piece, etc.) with anti-corrosion agent. The contacts in the battery shaft may not be lubricated.

7.3. SHARPENING THE BLADES

Any burrs may be removed and the blade smoothed only in the grinding area (Picture)! Chips or deep cracks cannot be ground away. The blades must be replaced in this case.

Tools required:

1. Clamping device (e.g., vise) with jaw protection
2. Grinder (e.g. angle grinder or belt grinder) with an abrasive that has a grain size of 80. A diamond file is adequate for small burrs.

Procedure:

1. Clamp the blade securely into the clamping device so that it cannot move, leaving the grinding area exposed (figure N).
2. Carefully de-burr the grinding area with the grinding machine (figure N).

7.4. REPAIR

Repairs may only be performed by HURST or personnel trained by HURST. When doing so, observe the information in the spare parts lists.

en

es

fr

pt

7.5. BATTERIES

If the devices are not used for a longer period, we recommend starting up the device with the appropriate battery 5 times after 30 days. Then charge the battery completely. This supports optimal function and availability of the battery and devices.

8. TROUBLESHOOTING

Fault	Check	Cause	Solution
The motor does not start after activating the star grip	The main switch is not illuminated although it has not been switched off	Device has not been used for 60 minutes and has switched off automatically	Switch the device on again with the main switch
		Battery dead	Recharge the battery or use another battery
	Blue ring on main switch flashes	Battery defective	Replace battery
	Blue ring on main switch flashes	There is a defect in the electronics	Repair by an authorized dealer, by personnel specially trained by HURST, or by HURST itself
Motor always runs	Star grip in middle position, device does not move, main switch illuminated or lights up?	Error in electronics	Finish work as usual, then switch off the unit at the main switch. Remove the battery. Repair by an authorized dealer, by personnel specially trained by HURST, or by HURST itself
Rescue device moves jerkily when operated		Air in the hydraulic system	Repair by an authorized dealer, by personnel specially trained by HURST, or by HURST itself
Rescue device moves slowly when operated	Temperature of device and battery below -10°C	Cold ambient temperature	Use devices normally, device will warm up with use
	Check charging state display	Rechargeable battery almost dead	Recharge the battery or use another battery

en

es

fr

pt

en

es

fr

pt



Fault	Check	Cause	Solution
Turbo function not available	Ambient temperature low		Use devices normally, device will warm up with use
		Changeover pressure reached	Perform movement without turbo function
	Warning light for electronics temperature lights up	Electronics temperature too high	Perform movement without turbo function
Cylinder pistons do not move when operated	Battery fully charged? Main switch illuminated?	Battery dead	Charge battery
		Battery defective	Replace battery
		Device defective	Repair by an authorized dealer, by personnel specially trained by HURST, or by HURST itself
Device doesn't perform at its given power.		Device defective	Repair by an authorized dealer, by personnel specially trained by HURST, or by HURST itself
Following release, the star grip doesn't return to the central/neutral position	Casing damaged or star grip operation not working smoothly?	Damage to the torsion spring for reset	Repair by an authorized dealer, by personnel specially trained by HURST, or by HURST itself
		Soiled valve or star grip	
		Defective valve	
		Other mechanical damage (e.g. star grip)	
Hydraulic fluid leakage on the piston rod		Defective rod seal	Repair by an authorized dealer, by personnel specially trained by HURST, or by HURST itself
		Damage to the piston	
The useful operating time between the individual charging cycles is less than 5 minutes, despite charging the batteries according to the instructions		Battery defective	Replace battery

9. EXPLANATION OF PICTOGRAMS FOR PERFORMANCE TABLES

All technical data is subject to tolerances. For this reason, there may be slight deviations between the data in the table and that of your device.

9.1. TECHNICAL DATA

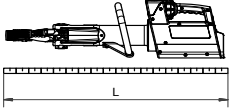
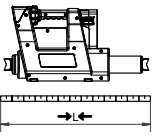
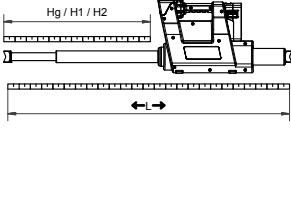
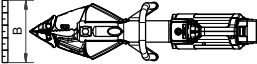
The technical data of the devices can be found starting on page 78.

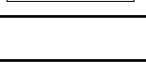
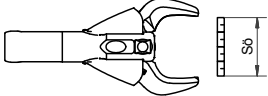



Symbol	Description	Remarks / abbreviation
	Length	(without battery)
	Length retracted	→L←
	Length extended	←L→
	Stroke	Hg
	Piston extension 1	H1
	Piston extension 2	H2
	Force piston 1	HSF1
	Width	(without battery)
	Height	
	Weight	(without battery)
	Weight with battery	5 Ah  9 Ah 
	Min. cutting opening	
	Cutting opening in accordance with EN	
	Max. cutting force	(rear-most cutting point)

en

es

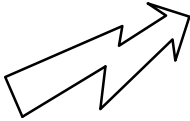
fr

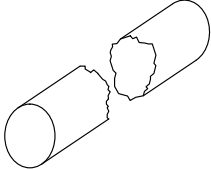
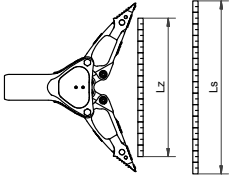
pt

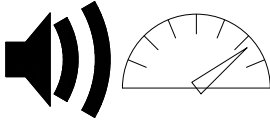
Symbol	Description	Remarks / abbreviation
	Nominal voltage	U
	Power consumption at nominal load	I
	Protection class	(up to 60 minutes and a depth of up to 3 meters)
	Round material \varnothing	
	Cutting class (EN 13204)	
	Cutting class (NFPA 1936)	
	Opening width	Ls
	Spreading force	HSF/LSF
	Min. spreading force	min. Fs (25mm from the tips)
	Max. spreading force	max. Fs *) computed value
	Traction path	Lz
	Pulling force	HPF/LPF
	Max. pulling force	max. Fz (with accompanying chain set)
	Operating temperature range	TB
	Storage temperature range	TL
	Acoustic pressure level at full load	L_{pAV}
	Acoustic power level at full load	L_{wAV}





9.2. OSCILLATION/VIBRATIONS

The total oscillation value / vibration value to which human arms should be exposed to is typically below 2.5 m/s².

Higher values may be measured for short periods as a result of interaction with the materials to be processed.

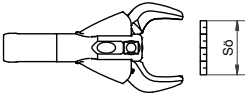
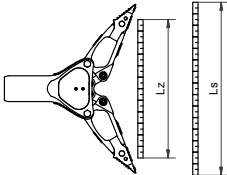
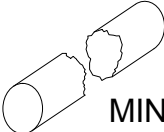
(The oscillations / vibrations were determined in accordance with DIN EN ISO 20643.)

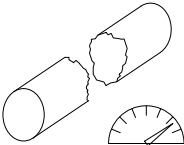
9.3. PRODUCT CAPACITY



Symbol	Description/note
	Type
	Cutter opening [mm]
	Spreading force [kN]
	Spreading width [mm]
	Classification based on the minimum performance of the cutter
	Weight [kg] (accurate to one decimal place)
	Cutter power
	Round material
	Flat material

en

es

fr

pt

Symbol	Description/note
	Round tube
	Square tube
	Rectangular tube

10. ACCESSORIES

10.1. BATTERIES

Only HURST lithium-ion rechargeable batteries may be used to operate eDRAULIC devices. Observe the separate operating instructions for the lithium-ion battery!

A special salt water battery is available from HURST for use in salt and sea water.

10.2. BATTERY CHARGER

Only the "eDRAULIC Power Pack Charger" may be used for the lithium-ion batteries. Observe the separate operating instructions for the charger.

10.3. POWER SUPPLY

For eDRAULIC devices, there is a power supply with which the devices can be connected directly to a power outlet. The power supply transforms the alternating current into direct current, so it can be used in place of the battery. Observe the separate operating instructions for the power supply.

10.4. CHAIN SETS

Chain sets and pulling adapters are required in order to perform pulling operations with the eDRAULIC spreaders and combination tools (see chapter, "Pulling"). Observe the separate operating instructions for the chains sets.

10.5. PEELING TIPS

Special peeling tips are required (see "Peeling" section) to be able to peel openings in sheet metal parts and vehicles using the eDRAULIC spreaders.

10.6. EXTENSIONS

Three different extensions (50, 150 and 270 mm) are available for the R 320 and CR 522 rescue rams.

11. INSTRUCTIONS REGARDING DISPOSAL

Please dispose of all packaging materials and removed items correctly. Electrical equipment, accessories and packaging should always be disposed of in an environmentally compatible way.

Only for EU countries:

Do not dispose of electrical equipment with your household waste!

According to the European Directive 2002/96/EC governing electrical and electronic waste and their application in national legislation, old electrical equipment must be separately collected and recycled in an environmentally compatible manner.

12. COMPLIANCE INFORMATION

CAN ICES-003(B) / NMB-003(B)

This device complies with part 15 of the FCC Rules and to RSS of Industry Canada.

Operation is subject to the following two conditions:

- (1) this device may not cause harmful interference, and
- (2) this device must accept any interference received, including interference that may cause undersired operation.

en

es

fr

pt







S 378 E3 CONNECT



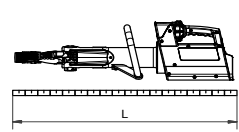
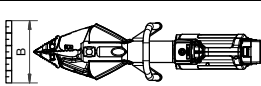
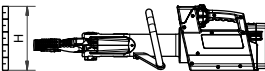
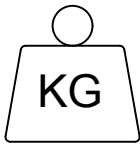

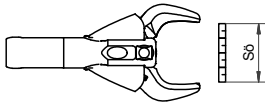
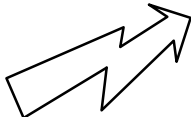
en

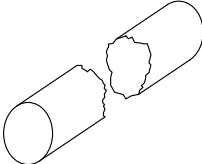
es

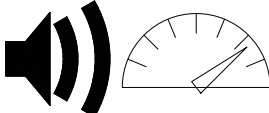
fr

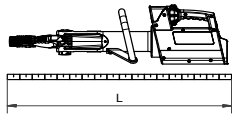
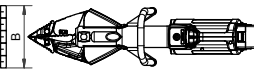
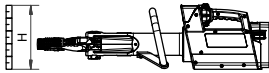
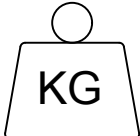
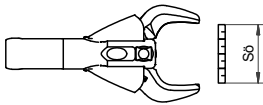
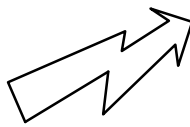
pt

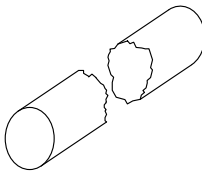
	[mm] / [in.]	846 / 33.3
	[mm] / [in.]	235 / 9.25
	[mm] / [in.]	253 / 9.96
	[kg] / [lbs.]	18,4 / 40.6
	[kg] 5 Ah 	19,6 / 43.2
	[kg] 9 Ah 	20 / 44.1
	[mm] / [in.]	202 / 7.99
	EN [mm] / [in.]	172 / 6.77
	U [V DC]	25,2
	I [A]	43
	IP	58
	[mm] / [in.]	Ø 33 / 1.3
	EN 13204	I
	NFPA 1936	A7/B8/C7/D8/E8
	TB [°C]	-20... +55
	TB [°F]	-4... +131
	TL [°C]	-30... +60
	TL [°F]	-22... +140
	EN [dB(A)]	73
	NFPA [dB(A)]	67

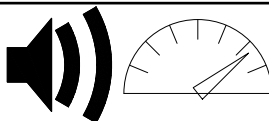
	[mm] / [in.]	907 / 35.7
	[mm] / [in.]	266 / 10.5
	[mm] / [in.]	253 / 9.96
	[kg] / [lbs.]	22,5 / 49.6
	[kg] 5 Ah	23,7 / 52.3
	[kg] 9 Ah	24,1 / 53.2
	[mm] / [in.]	205 / 8.06
	EN [mm] / [in.]	205 / 8.06
	U [V DC]	25,2
	I [A]	42
	IP	58
	[mm] / [in.]	Ø 42 / 1.65
	EN 13204	K
	NFPA 1936	A8/B9/C8/D9/E9/F5
	TB [°C]	-20... +55
	TB [°F]	-4... +131
	TL [°C]	-30... +60
	TL [°F]	-22... +140
	EN [dB(A)]	73
	NFPA [dB(A)]	67

en

es

fr

pt







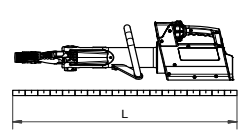
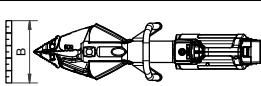
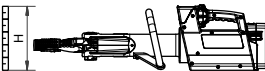

S 799 E3 CONNECT

en

es

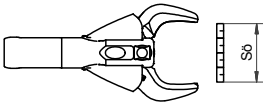
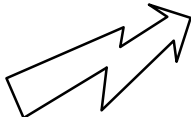
fr

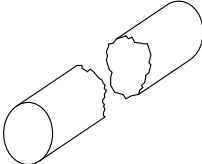
pt

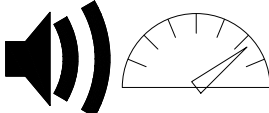
	[mm] / [in.]	930 / 36.6
	[mm] / [in.]	265 / 10.4
	[mm] / [in.]	253 / 9.96
	[kg] / [lbs.]	24,8 / 54.7
	[kg] 5 Ah 	26 / 57.4
	[kg] 9 Ah 	26,4 / 58.3
	[mm] / [in.]	204 / 8.03
	EN [mm] / [in.]	200 / 7.87
	U [V DC]	25,2
	I [A]	40
	IP	58
	[mm] / [in.]	Ø 45 / 1.77
	EN 13204	K
	NFPA 1936	A9/B9/C9/D9/E9/F5
	TB [°C]	-20... +55
	TB [°F]	-4... +131
	TL [°C]	-30... +60
	TL [°F]	-22... +140
	EN [dB(A)]	74
	NFPA [dB(A)]	69

en

es

fr

pt



SC 258 E3 CONNECT

en

es

fr

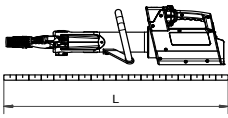
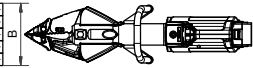
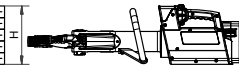
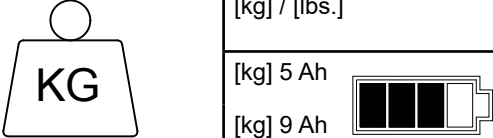
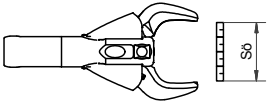
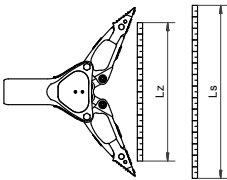
pt

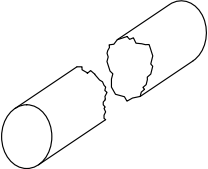
	[mm] / [in.]	792 / 31.2
	[mm] / [in.]	210 / 8.27
	[mm] / [in.]	253 / 9.96
	[kg] / [lbs.]	14,3 / 31.5
	[kg] 5 Ah	15,5 / 34.2
	[kg] 9 Ah	15,9 / 35.1
	[mm] / [in.]	233 / 9.2
	[kN] / [lbf.]	280 / 63000
	Ls [mm] / [in.]	321 / 12.6
	HSF - LSF [kN] / [lbf.]	29 / 6500 - 24 / 5400
	min. Fs [kN] / [lbf.]	32 / 7200
	max. Fs [kN] / [lbf.]	700 / 157000
	Lz [mm] / [in.]	330 / 13
	HPF - LPF [kN] / [lbf.]	37 / 8320 - 28 / 6300
	max. Fz [kN] / [lbf.]	34 / 7640
	U [V DC]	25,2
	I [A]	43
	IP	58
	[mm] / [in.]	Ø 26 / 1.02
	EN 13204	F
	NFPA 1936	A6/B6/C6/D7/E7/F4

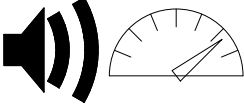
	TB [°C]	-20... +55
	TB [°F]	-4... +131
	TL [°C]	-30... +60
	TL [°F]	-22... +140
	EN [dB(A)]	70
	NFPA [dB(A)]	65

en

es

fr

pt



SC 358 E3 CONNECT

en

es

fr

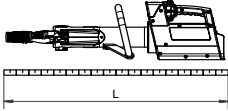
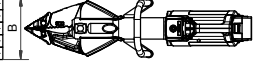
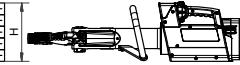
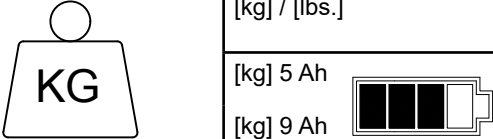
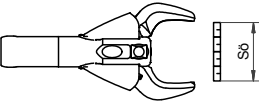
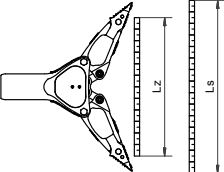
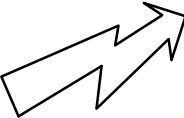
pt

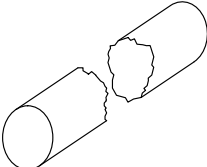
	[mm] / [in.]	876 / 34.5
	[mm] / [in.]	235 / 9.25
	[mm] / [in.]	253 / 9.96
	[kg] / [lbs.]	18,3 / 40.3
	[kg] 5 Ah	19,5 / 43
	[kg] 9 Ah	19,9 / 43.9
	[mm] / [in.]	309 / 12.2
	[kN] / [lbf.]	492 / 110600
	Ls [mm] / [in.]	368 / 14.5
	HSF - LSF [kN] / [lbf.]	43 / 9667 - 33 / 7419
	min. Fs [kN] / [lbf.]	38 / 8543
	max. Fs [kN] / [lbf.]	1500 / 337230
	Lz [mm] / [in.]	382 / 15
	HPF - LPF [kN] / [lbf.]	62 / 13940 - 43 / 9667
	max. Fz [kN] / [lbf.]	61 / 13714
	U [V DC]	25,2
	I [A]	43
	IP	58
	[mm] / [in.]	Ø 35 / 1.38
	EN 13204	I
	NFPA 1936	A7/B8/C7/D8/E7/F4

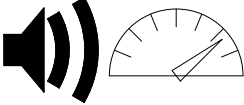
	TB [°C]	-20... +55
	TB [°F]	-4... +131
	TL [°C]	-30... +60
	TL [°F]	-22... +140
	EN [dB(A)]	74
	NFPA [dB(A)]	69

en

es

fr

pt



SC 758 E3 CONNECT

en

es

fr

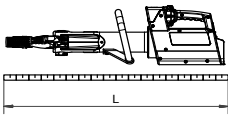
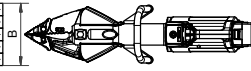
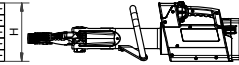
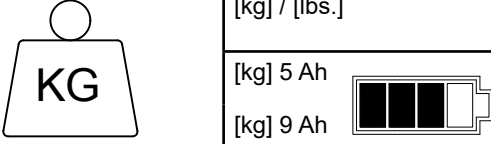
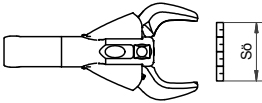
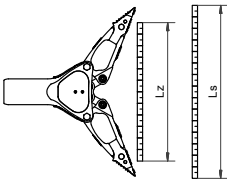
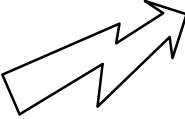
pt

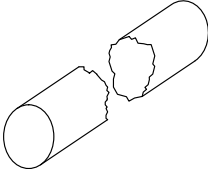
	[mm] / [in.]	980 / 38.6
	[mm] / [in.]	266 / 10.5
	[mm] / [in.]	253 / 9.96
	[kg] / [lbs.]	24,1 / 53.1
	[kg] 5 Ah	25,3 / 55.8
	[kg] 9 Ah	25,7 / 56.7
	[mm] / [in.]	400 / 15.7
	[kN] / [lbf.]	885 / 198955
	Ls [mm] / [in.]	475 / 18.7
	HSF - LSF [kN] / [lbf.]	49 / 11016 - 38 / 8543
	min. Fs [kN] / [lbf.]	52 / 11691
	max. Fs [kN] / [lbf.]	1500 / 337213
	Lz [mm] / [in.]	340 / 13.4
	HPF - LPF [kN] / [lbf.]	69 / 15512 - 52 / 11690
	max. Fz [kN] / [lbf.]	94 / 21132
	U [V DC]	25,2
	I [A]	40
	IP	58
	[mm] / [in.]	Ø 40 / 1.58
	EN 13204	J
	NFPA 1936	A8/B9/C9/D9/E9/F5

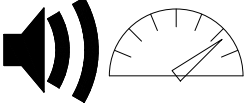
	TB [°C]	-20... +55
	TB [°F]	-4... +131
	TL [°C]	-30... +60
	TL [°F]	-22... +140
	EN [dB(A)]	76
	NFPA [dB(A)]	69

en

es

fr

pt







SP 333 E3 CONNECT



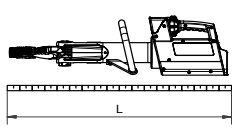
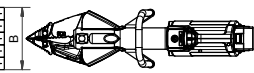
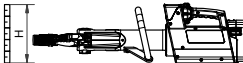

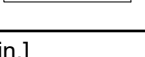
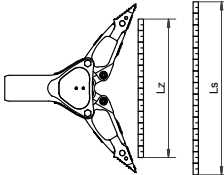

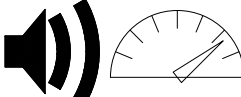

en

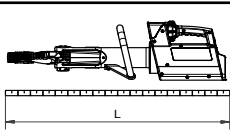
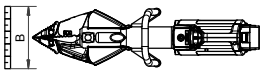
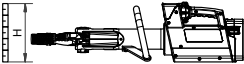
es

fr

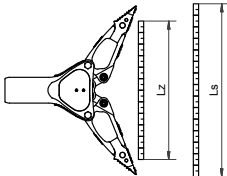
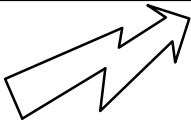
pt

	[mm] / [in.]	823 / 32.4
	[mm] / [in.]	256 / 10.1
	[mm] / [in.]	253 / 9.96
	[kg] / [lbs.]	17 / 37.5
	[kg] 5 Ah 	18,2 / 40.2
	[kg] 9 Ah 	18,6 / 41.7
	Ls [mm] / [in.]	600 / 23.6
	HSF-LSF [kN] / [lbf.]	63 / 14162 - 39 / 8768
	min. Fs [kN] / [lbf.]	42 / 9442
	max. Fs [kN] / [lbf.]	836 *) / 187940 *)
	Lz [mm] / [in.]	440 / 17.3
	HPF-LPF [kN] / [lbf.]	43 / 9667 - 23 / 5171
	max. Fz [kN] / [lbf.]	56 / 12589
	U [V DC]	25,2
	I [A]	42
	IP	58
	TB [°C]	-20... +55
	TB [°F]	-4... +131
	TL [°C]	-30... +60
	TL [°F]	-22... +140
	EN [dB(A)]	77
	NFPA [dB(A)]	73

	[mm] / [in.]	923 / 36.3
	[mm] / [in.]	265 / 10.4
	[mm] / [in.]	253 / 9.96
	[kg] / [lbs.]	19,8 / 43.6
	[kg] 5 Ah 	21 / 46.3
	[kg] 9 Ah 	21,4 / 47.3
	Ls [mm] / [in.]	730 / 28.7
	HSF-LSF [kN] / [lbf.]	72 / 16186 - 49 / 11016
	min. Fs [kN] / [lbf.]	52 / 11690
	max. Fs [kN] / [lbf.]	658 *) / 147924 *)
	Lz [mm] / [in.]	569 / 22.4
	HPF-LPF [kN] / [lbf.]	46 / 10341 - 28 / 6295
	max. Fz [kN] / [lbf.]	58 / 13039
	U [V DC]	25,2
	I [A]	45
	IP	58
	TB [°C]	-20... +55
	TB [°F]	-4... +131
	TL [°C]	-30... +60
	TL [°F]	-22... +140
	EN [dB(A)]	79
	NFPA [dB(A)]	71

en

es

fr

pt







SP 777 E3 CONNECT

en

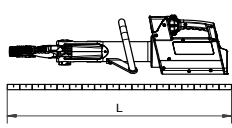
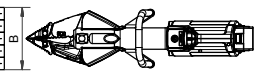
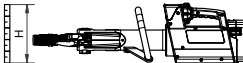
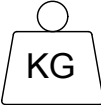

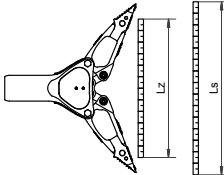
es

fr

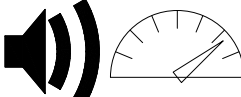
pt

	[mm] / [in.]	997 / 39.3
	[mm] / [in.]	309 / 12.2
	[mm] / [in.]	253 / 9.96
	[kg] / [lbs.]	23,4 / 51.6
	[kg] 5 Ah 	24,6 / 54,2
	[kg] 9 Ah	25 / 55.1
	Ls [mm] / [in.]	813 / 32.0
	HSF-LSF [kN] / [lbf.]	85 / 19110 - 59 / 13260
	min. Fs [kN] / [lbf.]	63 / 14160
	max. Fs [kN] / [lbf.]	600 *) / 134900 *)
	Lz [mm] / [in.]	655 / 25.8
	HPF-LPF [kN] / [lbf.]	49 / 11016 - 30 / 6744
	max. Fz [kN] / [lbf.]	60 / 13490
	U [V DC]	25,2
	I [A]	43
	IP	58
	TB [°C]	-20... +55
	TB [°F]	-4... +131
	TL [°C]	-30... +60
	TL [°F]	-22... +140
	EN [dB(A)]	74
	NFPA [dB(A)]	69

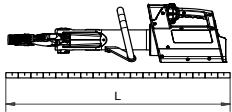
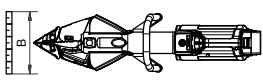
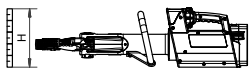
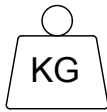
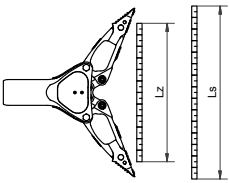
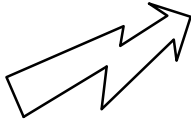
M 40 E3 CONNECT

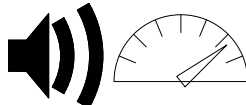
	[mm] / [in.]	1106 / 43.6
	[mm] / [in.]	309 / 12.1
	[mm] / [in.]	253 / 9.96
	[kg] / [lbs.]	24,9 / 54.9
	[kg] 5 Ah	26,1 / 57.5
	[kg] 9 Ah	26,5 / 58.4
	Ls [mm] / [in.]	1018 / 40.1
	HSF-LSF [kN] / [lbf.]	45 / 10120 - 72 / 16190
	min. Fs [kN] / [lbf.]	47 / 10570
	max. Fs [kN] / [lbf.]	500 *) / 112400 *)
	Lz [mm] / [in.]	898 / 35.3
	HPF-LPF [kN] / [lbf.]	42 / 9442 - 23 / 5171
	max. Fz [kN] / [lbf.]	50 / 11240
	U [V DC]	25,2
	I [A]	43
	IP	58
	TB [°C]	-20... +55
	TB [°F]	-4... +131
	TL [°C]	-30... +60
	TL [°F]	-22... +140
	EN [dB(A)]	79
	NFPA [dB(A)]	73

en

es

fr

pt





R 320 E3 CONNECT





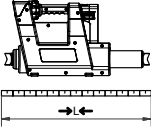
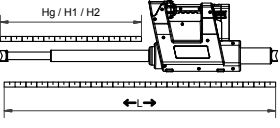
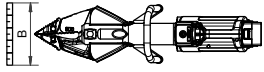
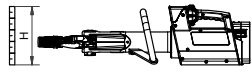

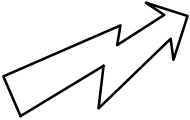
en

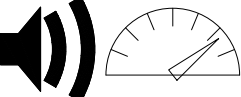
es

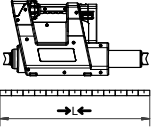
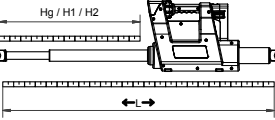
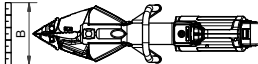
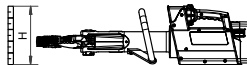
fr

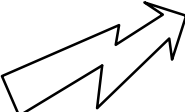
pt

	<p>→L← [mm] / [in.]</p>	<p>340 / 13.4</p>
	<p>←L→ [mm] / [in.]</p>	<p>640 / 25.2</p>
	<p>Hg [mm] / [in.]</p>	<p>300 / 11.8</p>
	<p>H1 [mm] / [in.]</p>	<p>164 / 6.5</p>
	<p>H2 [mm] / [in.]</p>	<p>136 / 5.3</p>
	<p>HSF1 [kN] / [lbf.]</p>	<p>127 / 28600</p>
	<p>HSF2 [kN] / [lbf.]</p>	<p>60 / 13500</p>
	<p>[mm] / [in.]</p>	<p>200 / 7.9</p>
	<p>[mm] / [in.]</p>	<p>326 / 12.8</p>
	<p>[kg] / [lbs.]</p>	<p>13,2 / 29.1</p>
	<p>[kg] 5 Ah</p>	<p>14,4 / 31.8</p>
	<p>[kg] 9 Ah </p>	<p>14,8 / 32.7</p>
	<p>U [V DC]</p>	<p>25,2</p>
	<p>I [A]</p>	<p>44</p>
	<p>IP</p>	<p>58</p>
	<p>TB [°C]</p>	<p>-20... +55</p>
	<p>TB [°F]</p>	<p>-4... +131</p>
	<p>TL [°C]</p>	<p>-30... +60</p>
	<p>TL [°F]</p>	<p>-22... +140</p>
	<p>EN [dB(A)]</p>	<p>78</p>
	<p>NFPA [dB(A)]</p>	<p>72</p>

	→L← [mm] / [in.]	502 / 19.8
	←L→ [mm] / [in.]	1126 / 44.3
	Hg [mm] / [in.]	624 / 24.6
	H1 [mm] / [in.]	325 / 12.8
	H2 [mm] / [in.]	299 / 11.8
	HSF1 [kN] / [lbf.]	127 / 28600
	HSF2 [kN] / [lbf.]	60 / 13500
	[mm] / [in.]	140 / 5.51
	[mm] / [in.]	327 / 12.9
	[kg] / [lbs.]	17,2 / 37.9
	[kg] 5 Ah	18,4 / 40.6
	[kg] 9 Ah 	18,8 / 41.5
	U [V DC]	25,2
	I [A]	45
	IP	58
	TB [°C]	-20... +55
	TB [°F]	-4... +131
	TL [°C]	-30... +60
	TL [°F]	-22... +140
	EN [dB(A)]	73
	NFPA [dB(A)]	69

en

es

fr

pt





R 521 E3 CONNECT





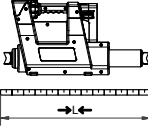
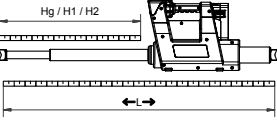
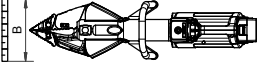
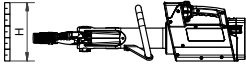

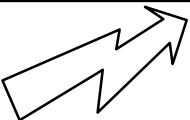

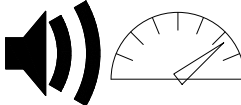
en

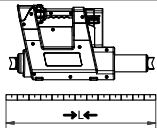
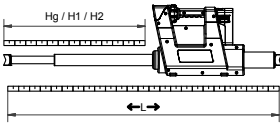
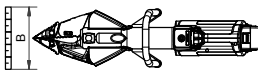
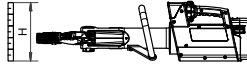
es

fr

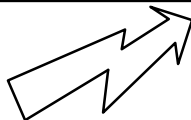
pt

	→L← [mm] / [in.]	579 / 22.8
	←L→ [mm] / [in.]	1359 / 53.5
	Hg [mm] / [in.]	780 / 30.7
	H1 [mm] / [in.]	403 / 15.6
	H2 [mm] / [in.]	377 / 14.8
	HSF1 [kN] / [lbf.]	127 / 28600
	HSF2 [kN] / [lbf.]	60 / 13500
	[mm] / [in.]	140 / 5.51
	[mm] / [in.]	327 / 12.9
	[kg] / [lbs.]	18,9 / 41.7
	[kg] 5 Ah	20,21/ 44.4
	[kg] 9 Ah 	20,5 / 45.3
	U [V DC]	25,2
	I [A]	45
	IP	58
	TB [°C]	-20... +55
	TB [°F]	-4... +131
	TL [°C]	-30... +60
	TL [°F]	-22... +140
	EN [dB(A)]	72
	NFPA [dB(A)]	69

	→L← [mm] / [in.]	627 / 24.7
	←L→ [mm] / [in.]	1503 / 59.2
	Hg [mm] / [in.]	876 / 34.5
	H1 [mm] / [in.]	451 / 17.8
	H2 [mm] / [in.]	425 / 16.7
	HSF1 [kN] / [lbf.]	127 / 28600
	HSF2 [kN] / [lbf.]	60 / 13500
	[mm] / [in.]	140 / 5.51
	[mm] / [in.]	327 / 12.9
	[kg] / [lbs.]	20,4 / 45
	[kg] 5 Ah 	21,6 / 47.7
	[kg] 9 Ah 	22 / 48.6
	U [V DC]	25,2
	I [A]	42
	IP	58
	TB [°C]	-20... +55
	TB [°F]	-4... +131
	TL [°C]	-30... +60
	TL [°F]	-22... +140
	EN [dB(A)]	75
	NFPA [dB(A)]	69

en

es

fr

pt







CR 522 E3 CONNECT

en

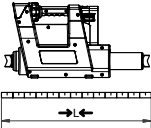
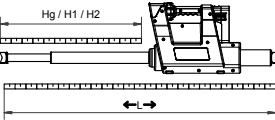
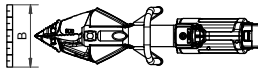
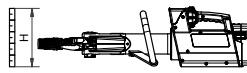
es

fr

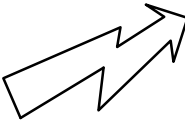
pt

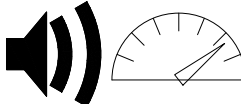
	→L← [mm] / [in.]	657 / 25.8
	←L→ [mm] / [in.]	1533 / 60.3
	Hg [mm] / [in.]	876 / 34.5
	H1 [mm] / [in.]	451 / 17.8
	H2 [mm] / [in.]	425 / 16.7
	HSF1 [kN] / [lbf.]	127 / 28600
	HSF2 [kN] / [lbf.]	60 / 13500
	[mm] / [in.]	140 / 5.51
	[mm] / [in.]	327 / 12.9
	[kg] / [lbs.]	21,1 / 46.5
	[kg] 5 Ah 	22,3 / 49.2
	[kg] 9 Ah 	22,7 / 50
	U [V DC]	25,2
	I [A]	43
	IP	58
	TB [°C]	-20... +55
	TB [°F]	-4... +131
	TL [°C]	-30... +60
	TL [°F]	-22... +140
	EN [dB(A)]	75
	NFPA [dB(A)]	69

en

es

fr

pt

A.)

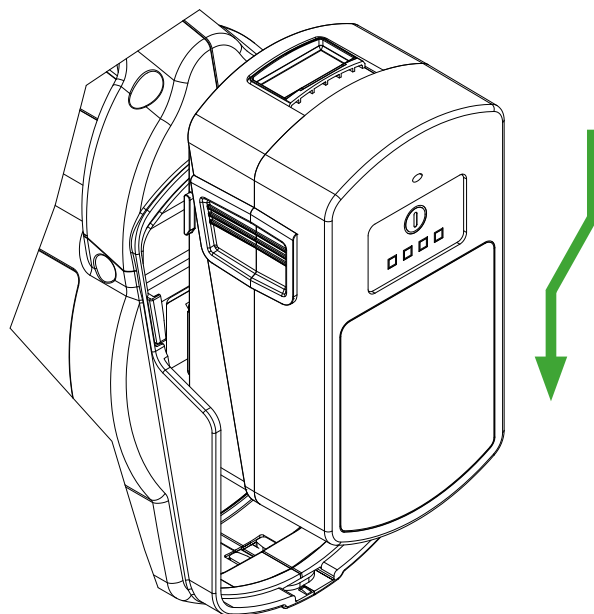

B.)

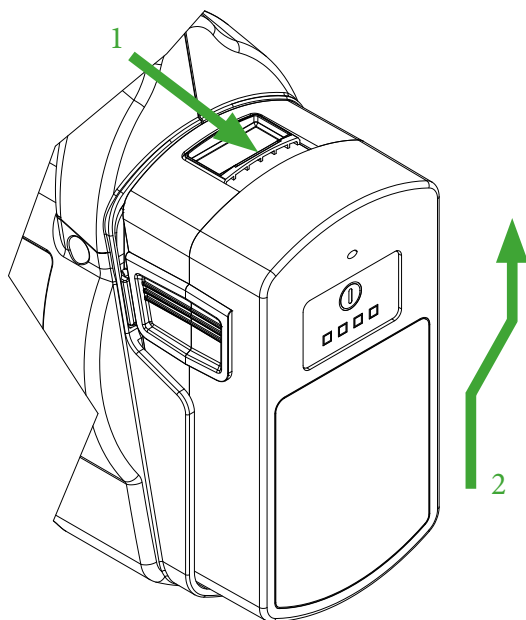

en

es

fr

pt

C.)

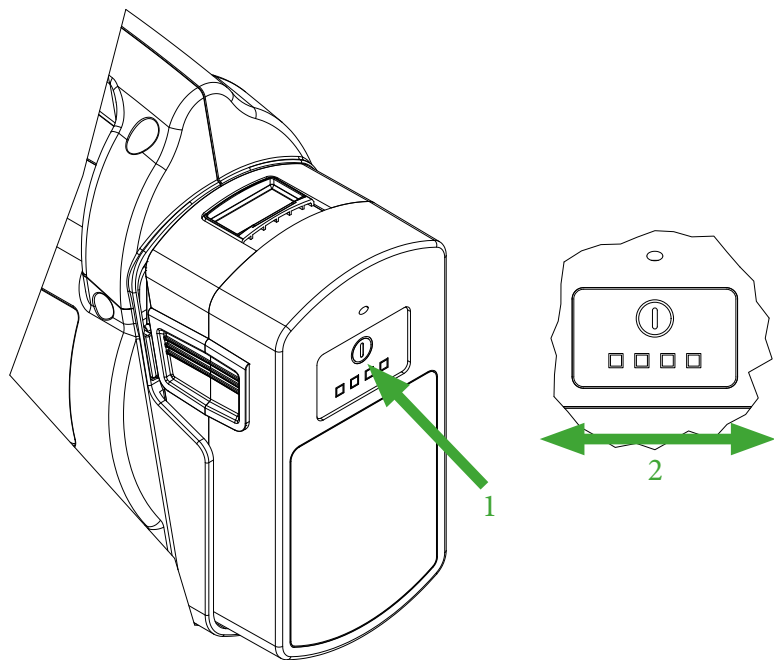

D.)

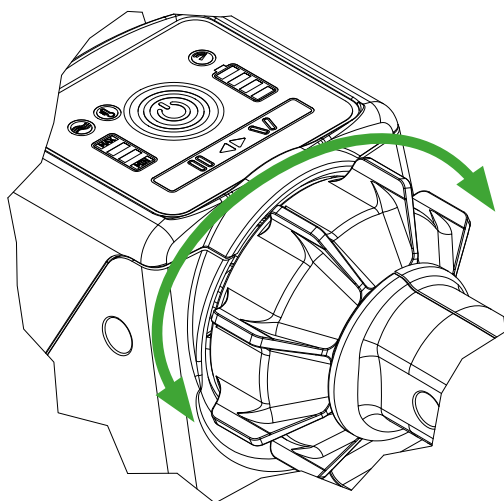

en

es

fr

pt

E.)

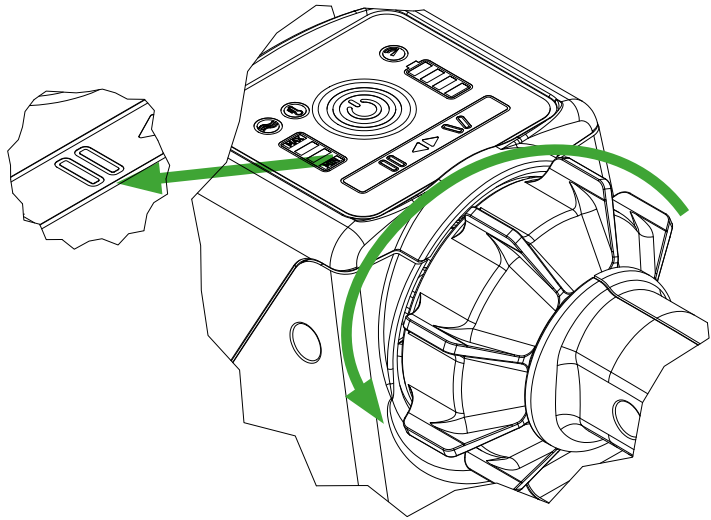

F.)

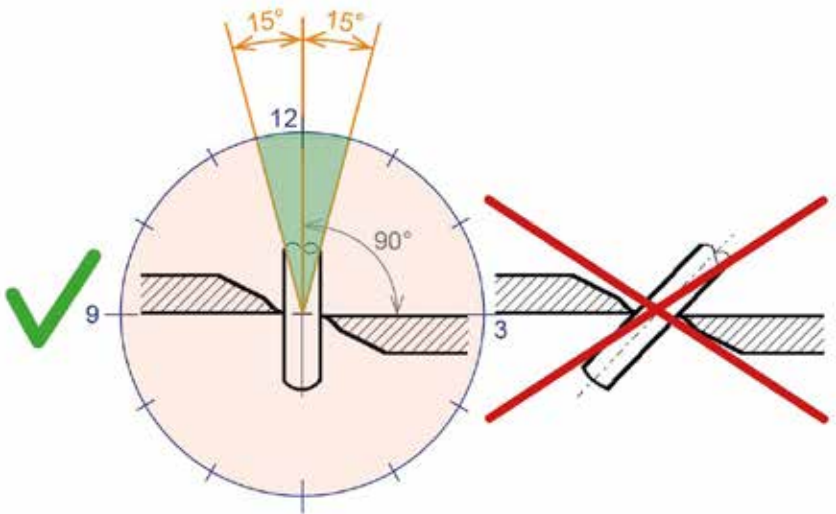

en

es

fr

pt

G.)

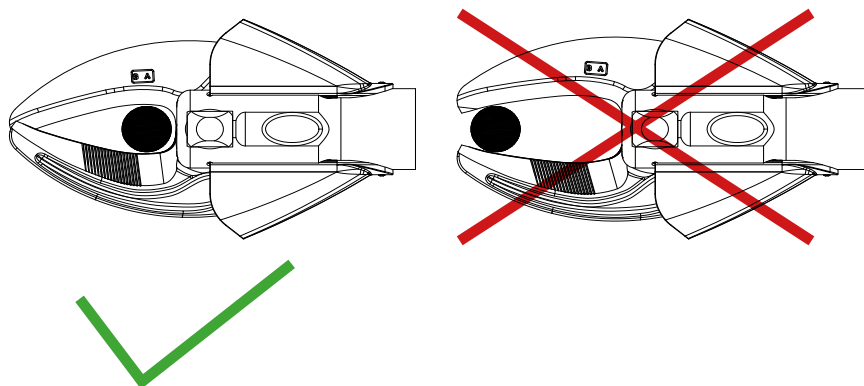

H.)

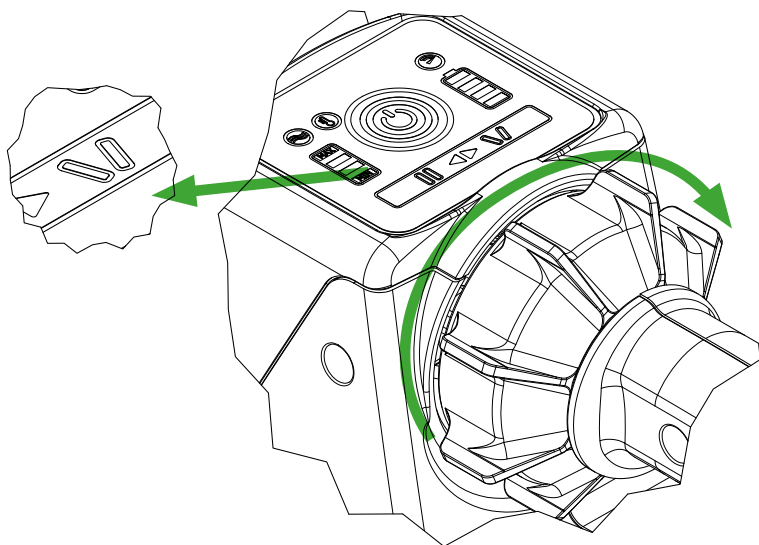

en

es

fr

pt

J.)

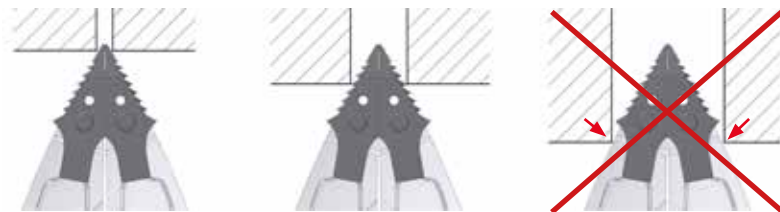

en

es

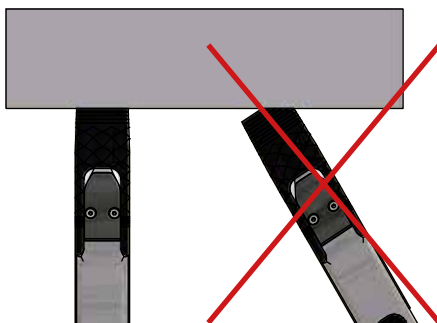

K.)

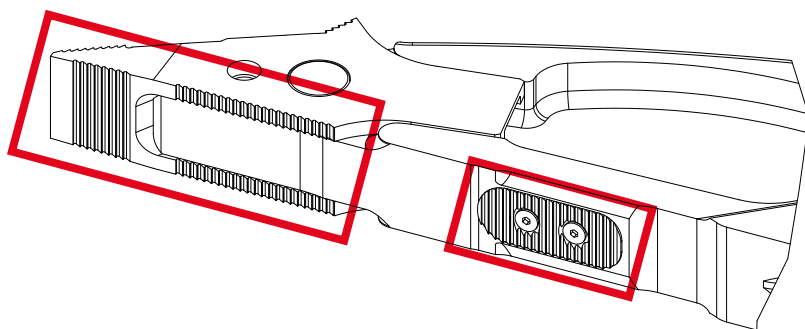

fr

pt

L.)

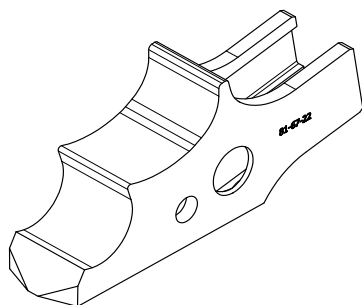

en

es

M.)

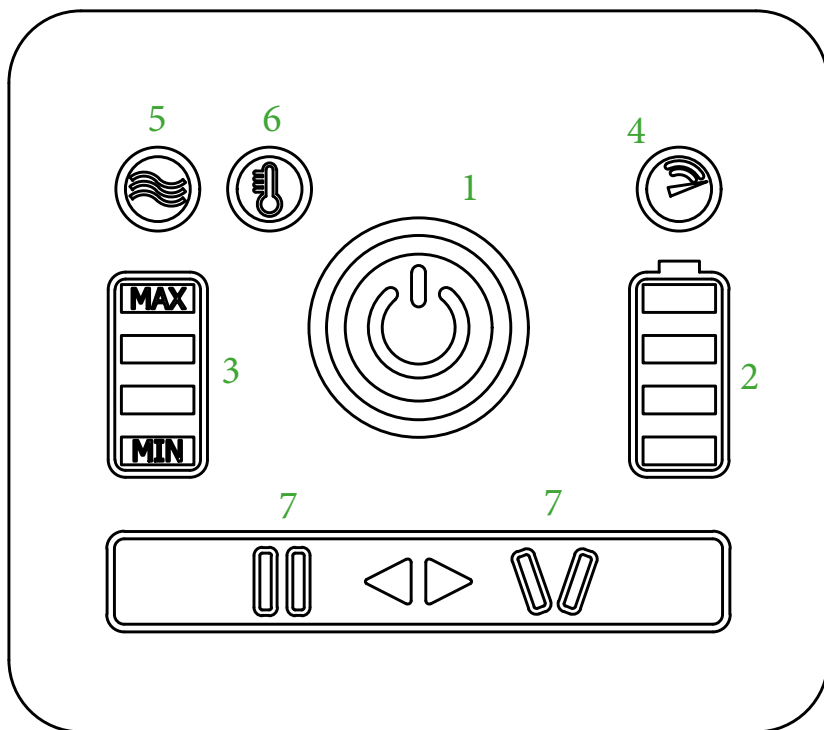

fr

pt

N.)

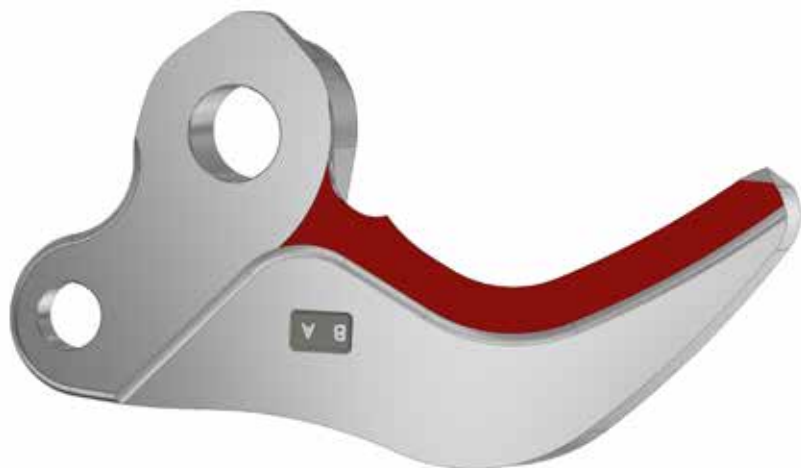

en

es

O.)

fr

	711 N. Post Road Shelby, NC 28150 USA	Tel.: 1-800-537-2659 www.jawsoflife.com contacthurst@idexcorp.com
272699000 S 799 E3 Connect		
70 MPa	24,8 Kg	
25,2 VDC; Imin 7 A Imax 40 A		
Ser. No: 2022210001	Apr - 2022	Hydraulic Fluid: Mineral Oil
		THIS POWERED RESCUE TOOL MEETS THE REQUIREMENTS OF NFPA 1936 STANDARD ON RESCUE TOOLS, 2020 EDITION. DO NOT REMOVE THIS LABEL

pt

P.)



Q.)

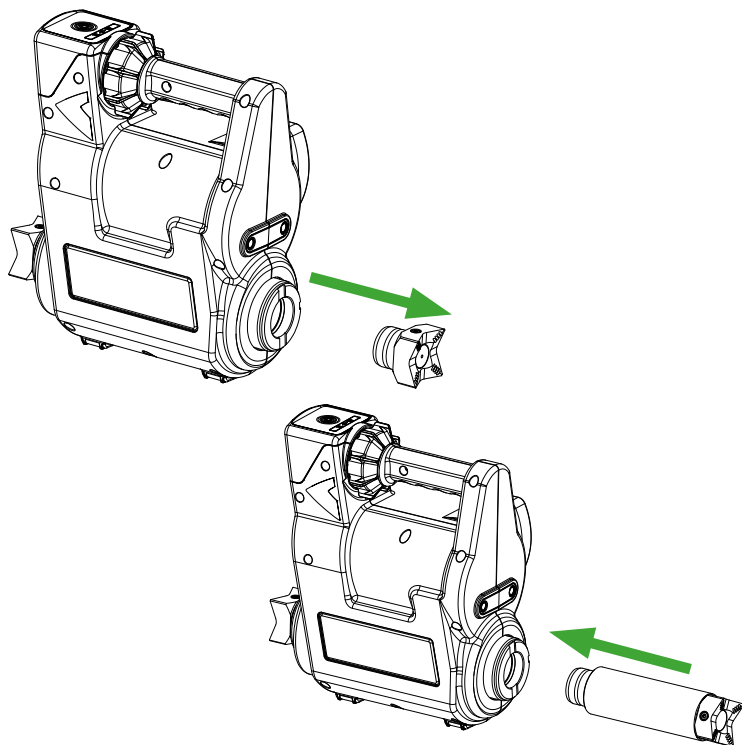

en

es

fr

pt

en

es

fr

pt

en

es

fr

pt



A Trusted **IDEX Fire & Safety** Brand

711 North Post Road
Shelby, NC 28150

Email: contacthurst@idexcorp.com

Phone: 1-800-537-2659

Web: www.jawsoflife.com

Subject to Revision